

ELEVATION VIEW

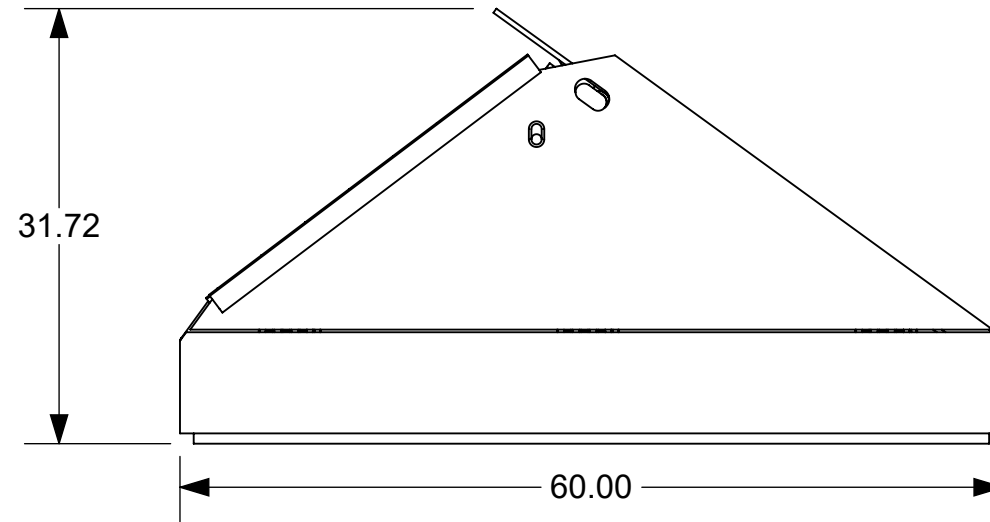
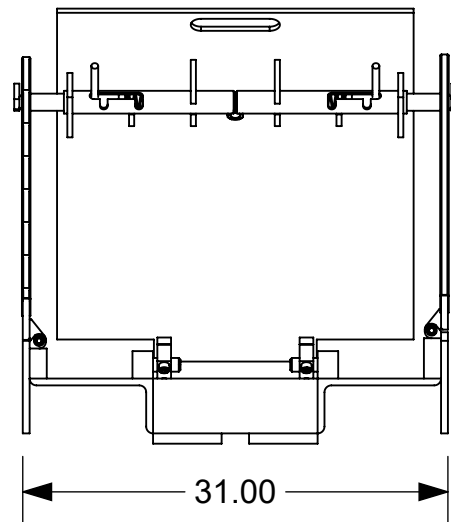
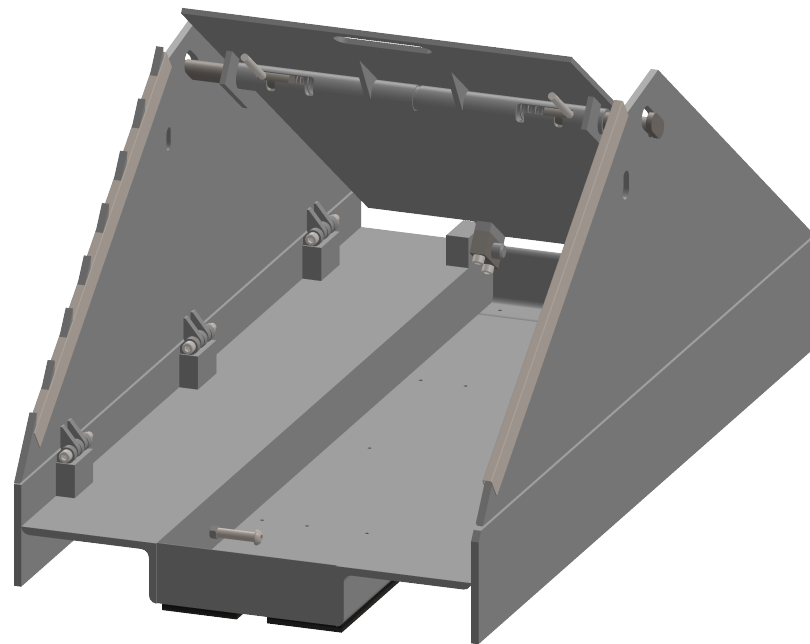
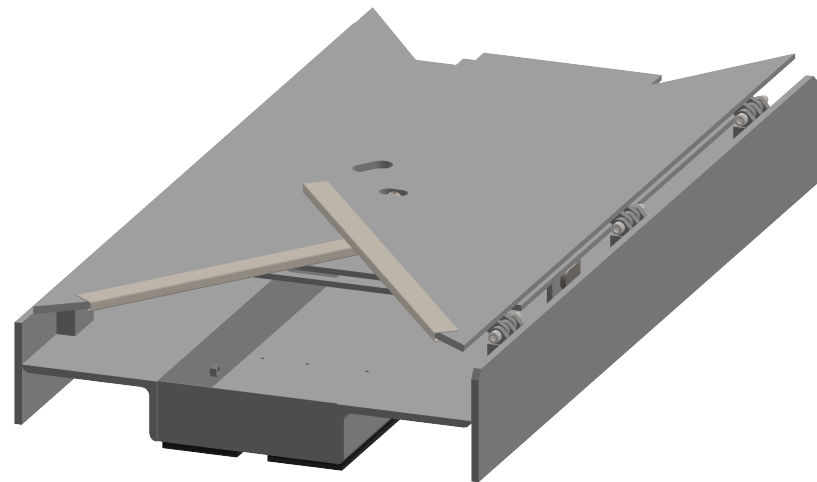

THIS FOLDABLE, MANUAL, WEDGE BARRIER IS DESIGNED TO BE EASILY MOBILE AND DEPLOYABLE ON EXISTING CONCRETE OR ASPHALT ROADWAYS OR SIDEWALKS. NO EXCAVATION OR SUB-SURFACE PREPARATION IS REQUIRED.

ENGINEER RATING OF PU30 @ 5000 LBS/30MPH

SIMPLE STACKABILITY AND MINIMAL FOOTPRINT ALLOWS FOR EFFICIENT STORAGE.

PORTABLE USING A STANDARD PALLET JACK, STRADDLE STACKER, MINI FORKLIFT, OR DELTA'S MP100 TRANSPORTER.

EASY TO SETUP, REQUIRES NO INDEPTH TRAINING OR CERTIFICATION TO DEPLOY BY THE AVERAGE PERSON.

INCLUDES SPRING LOADED LOCKS FOR SAFETY AND SPEEDY DEPLOYMENT.

OPTIONAL TO LINK TOGETHER IN AN ARRAY FOR INCREASED SECURITY

COLOR AND FINISH TO BE DETERMINED BY CUSTOMER.

TOTAL WEIGHT EACH: 786.54

THIS DRAWING, UNLESS OTHERWISE NOTED, REMAINS THE CONFIDENTIAL PROPERTY AND TRADE SECRET OF DELTA SCIENTIFIC CORPORATION. IT SHALL NOT BE DISCLOSED, REPRODUCED OR USED FOR MANUFACTURE, DESIGN OR CONSTRUCTION WITHOUT THE EXPRESS AUTHORIZATION OF DELTA SCIENTIFIC CORPORATION. THE RECIPIENT BY ACCEPTING THIS DRAWING, ASSUMES CUSTODY THEREOF AND UNDER THE ABOVE TERMS AGREES NOT TO ALLOW USE OF BY UNAUTHORIZED PERSONS.

© 2023
ALL RIGHTS RESERVED

UNLESS OTHERWISE NOTED DIMENSIONS ARE IN INCHES

TOLERANCES
.X = ±.060/FT
.XX = ±.030/FT
.XXX = ±.010/FT
ANGLES = 5°

SURFACE FINISH
125
REMOVE ALL BURRS AND BREAK SHARP EDGES 02 MAX

 DELTA SCIENTIFIC CORPORATION 40355 DELTA LANE PALMDALE, CA 93551 U.S.A. (861) 575-1000 FAX (861) 575-1109			
MP100 FOLDABLE PORTABLE WEDGE BARRIER GENERAL ARRANGEMENT			
DRAWN BY RO	DATE 6/6/2024	DRAWING NO. 17631	REV. -
CHKD BY	DATE	SCALE: 1:14	
APPV BY	DATE	SHEET SHEET 1 OF 1	