

DELTA SCIENTIFIC

HIGH SECURITY PRODUCT CATALOGUE

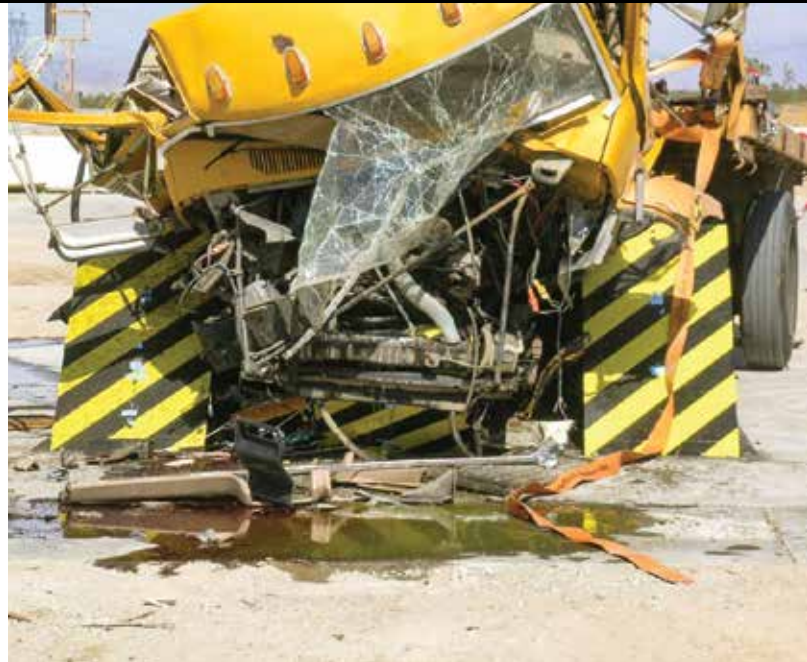

deltascientific.com
(661) 575-1100
info@deltascientific.com

A Letter From Our President

One of the biggest challenges faced today is trying to lead. True leaders are responsible for their own actions as well as the actions of their team. Leadership is not always about making the right decision, but many times about making the best decision for the team, oftentimes at the expense of pride or ego. It is the relationship the leader builds with the team that is frequently the difference between success and mediocrity.

As the leader in the vehicle barrier world, the Delta Scientific family understands the obligation that comes with being a leader. As a business that thrives as a result of our many relationships, we take ultimate responsibility for our successes, as well as our shortcomings. The entire Delta team takes complete responsibility for the quality, delivery, and performance of our systems. We listen to client feedback from the amazing people we have been fortunate enough to serve, and use it. There is a reason there are no model years for Delta products – our engineers have them under constant review for improvement. Like any true leader striving toward mastery, we know how to admit when we could have done better, and we focus on that improvement until we can see results.

Welcome to Delta Scientific. I started here nearly 15 years ago as an applications engineer, helping people discover the best fit of safety and security for each customer's site. This place has introduced me to some of the hardest working and brightest people I am now thankful to call my friends. Most importantly, this place has given me a larger family, a team of Delta employees that I am proud to boast about as the most accountable in the industry. The care these people give to the products you purchase shows in the effective design and durable workmanship. There is a reason these systems work so well. The people that sell them, build them, and support them, care. They are each leaders. They each have the power to help you move closer to your goal of a reliable, effective vehicle barrier solution for your facility or your client.

Along with the best systems in the world against vehicle attack, the installation of a Delta Barrier System also brings with it a relationship between our family and your organization.

Let's lead together and let's start a relationship.

Please challenge us. We welcome it. It is what built this company, and it is what is going to keep this company strong, for you, for decades to come.

Sincerely,



Keith Bobrosky
President
keith@deltascientific.com



Worldwide Since 1974



Delta Scientific Corporation is the world's leading manufacturer of vehicle access control equipment. Delta Scientific has been engineering and manufacturing vehicle access control equipment and selling its products worldwide since 1974.

With 260,000 square feet of manufacturing space, the Delta Scientific Corp Palmdale, CA Manufacturing Facility allows us to meet the increased requirements and demands of its continually growing domestic and international customer base. Delta has the ability to ramp up capacity very quickly to accommodate large projects with demanding lead times. Flexibility is a key ingredient to the Delta Scientific manufacturing model. With over 50 different barrier models built in house, Delta's experienced team of fabricators and welders can handle any job.

Delta Scientific Corporation prides itself on innovation and its engineering department leads the way. With both mechanical and electrical engineers on staff, Delta is able to aggressively pursue custom projects and new technology. The Delta team interfaces

closely with architects and professional engineers of all trades to ensure the feasibility of product application. Reliability and sustainability are two key components of our barriers. New products are constantly emerging from the collaborative works of Delta Scientific's engineering teams as they meet the ever-changing landscape of the barrier industry. Whether it's new touch screen controls or a new barrier design, Delta is at the forefront, continuing to lead the industry.











50 years in business

Over 100 different product designs

50+ successful certified crash tests

260,000 square feet of manufacturing space

CONTENTS

4-5	Delta Solutions
6-7	Safety Act Certified Products
 8-16	High Security Wedge Barricades DSC550, HD300, DSC501, DSC2000, DSC207S, HD2055, TT207S, HD200
 17-22	Crash Rated Beam Barricades DSC7000, DSC7500, DSC7090, TT212EC, TT212E, TT212, TT218, TT218E, TT218EC
 23-32	High Security Bollards DSC720-1M, DSC720, DSC701, DSC800, DSC635, DSC633, DSC600, DSC650, DSC305
 33-39	High Security Gates DSC288, TT280, TT300, SC3000S, SGC1000, DSC8000
 40-47	Portable Barriers for Vehicle Security Control MP5000, MP5000 M50, DSC1000, DSC900, DSC1100, IP500, TB100, TB150, DSC1500
 48-53	Surface Mounted Wedge Barricades TT207SFM, DSC1200, DSC1450, DSC1425, TW2015, TW4030
 54-58	Guard Booths High Security Guard Booth, Standard, Custom and Ticket Guard Booths, Mail Room Inspection Bio Booth
 59-62	Parking Lot Gates & Traffic Teeth
 63-66	Parking Control Gates
 67-68	Barricade Control Systems
 69	Under Vehicle Inspection Lights
70	Product Support and Service
71	Contact Information

Barricade Protection Solutions

to meet the needs of many industries.



National Infrastructure Security

Delta Scientific crash rated barriers have been called upon to protect critical infrastructure around the world. Over decades of defending critical infrastructure, Delta Scientific has developed barricades and supporting technologies to meet the diverse needs of these facilities.



Military Security

Military bases face constant threats. These facilities require constant accessibility while maintaining utmost security. Delta Scientific has been at the forefront of military physical crash rated security for decades. Delta Scientific barriers have never failed to neutralize an attacking vehicle.



Government Buildings Security

Delta Scientific has had a strong relationship with the US government dating back to our founder Harry Dickinson's patent on the first spike teeth in the 1970's.



Airports and Seaports Security

The Nation's Seaports and Airports throughput thousands of people and billions of dollars' worth of materials every day. These ports comprise of massive plots of land located amongst densely populated communities.



Private Sector Security

Bollards, Wedges, Beams, traffic arms, and gates designed and manufactured by Delta Scientific are being used all around the world to secure businesses across every major industry.



Campus Security

College and University campuses pose a unique set of challenges for security personnel. These campuses can cover multiple city blocks with roadways both private and public passing through.

Delta Scientific provides security barricade solutions for many different industries across the globe. Chosen by government agencies, military bases, critical infrastructure installations and commercial industries for protection solutions obtained that can be achieved from just one supplier.

Delta Scientific handles vehicle barricade systems and more from the outside and inside, with installation, maintenance and full service.



Event Security

No barrier manufacturer has done more for event security than Delta Scientific. Street fairs, festivals, concerts, premieres, sporting events, conventions and street caterings around the nation have implemented Delta Scientific portable barricades to protect event attendees from vehicles.



Traffic Management

Traffic management takes many forms. Traffic management can involve closing a roadway during a major city event such as a motion picture awards show, or traffic management can simply entail a traffic arm that raises and lowers after a fee has been paid in a parking garage.



Public Spaces Security

Military, Government, Airports, Seaports and Stadium leaders have made protecting their personnel and assets against vehicular terror attacks a major priority over the years.

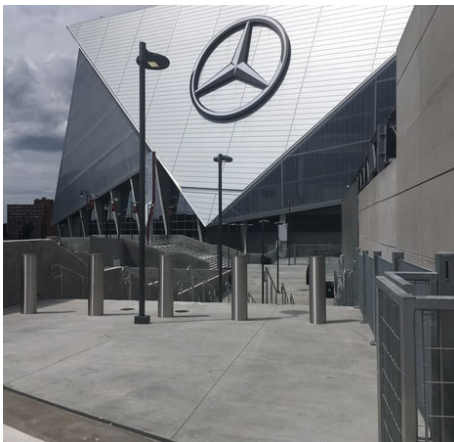

Stadium Security

Few places have a greater security concern than Stadiums and Arenas. Delta Scientific barriers have been leading the charge in securing the nations stadiums from vehicle borne terrorist attacks and errant driver incidents.



Custom Engineering

Delta Scientific has performed more than fifty crash tests working with a number of government agencies and crash test facilities, since its inception in 1974.



Crash Rated Systems

Some of Delta Scientific barricades, bollards, gates, beams and vehicle access control models are crash-certified. They are classified according to the type of barricade, barrier or bollard.



Safety Act Certified Products

The SAFETY Act certification places Delta Scientific's active and passive anti-ram barriers on the "Approved Product list for Homeland Security." This certification is the highest level of liability protection.

The Department of Homeland Security has completed its review of Active and Passive Barriers, and has granted Delta Scientific coverage under the federal law known as the "Support Anti-terrorism by Fostering Effective Technology Act" (the "SAFETY Act"). Delta Scientific has achieved the highest level of certification with the Red Seal. This means Delta Scientific is actually deemed 'Certified' and not 'Designated' as you will see with other vendors that carry a Blue Seal. Why is this important? Under the Designation label, DHS caps a seller's insurance liability in the event of an act of terrorism among several other legal protections. Under the Certified label, in addition to the Designation benefits, the seller can assert the Government Contractor Defense for any claims arising from acts of terrorism. This is just another reason to choose Delta Scientific for your security needs.

The SAFETY Act eliminates liability that could arise out of a terrorist attack for sellers whose anti-terror products have been reviewed and approved by the DHS in America's fight against terrorism. The SAFETY Act lawsuit protection coverage will result in significantly lower liability exposure for Delta Scientific and its customers, should a future act of terrorism occur.

These lawsuit protections extend to Delta Scientific's customers should a future act of terrorism occur and lawsuits follow alleging that Delta Scientific's physical security products failed to prevent the terrorism. Delta Scientific, the contractors that install our products, the security integrators, architects and engineers that specify our products, and the end use customers that use our qualified physical security products on their facilities, all benefit from the liability protection afforded by the SAFETY Act. The entire supply chain (manufacturer, specifiers, installers, vendors, and customers) also benefit from the coverage Delta Scientific receives from SAFETY Act Certification.

Should a lawsuit happen, our customers' liability would be strictly limited, if not nonexistent, in most cases, because they purchased Delta Scientific's SAFETY Act approved products and services. This may also create an opportunity for Delta Scientific's customers to lower insurance premiums given the elimination of risk of lawsuits.

For further information about the SAFETY Act and how it relates to Delta Scientific's Active and Passive Barrier products please contact our team.



Safety Act Certified Product Chart

Model Number	Product Type	Crash Rating
MP5000	Portable Wedge Barrier	M40
HD300	Wedge Barrier	M50
DSC550	Open Frame Wedge Barrier	M50
DSC600	Shallow Foundation Fixed Bollard	K12
DSC633	Shallow Foundation Fixed Bollard	M30
DSC635	Shallow Foundation Fixed Bollard	M50
DSC650	Shallow Foundation Fixed Bollard	PU50
DSC720-1M	Deep Foundation Bollard	M50
DSC800	Deep Foundation Bollard	K4
DSC288	Crash Gate	M50
DSC1200	Surface Mounted Wedge Barrier	K4
DSC2000	Wedge Barrier	K12
DSC501	Wedge Barrier	K12 and K4
DSC7000	Beam Barrier	K12
DSC1500	Portable Beam Barrier	M30
DSC7090	Bolt Down Beam Barrier	M30
MP5000-M50	Portable Wedge Barrier	M50
TB100	Portable Bollard Array	M30
TB150	Portable Bollard Array	M50
HD200	Wedge Barrier	M30
DSC550	Open Frame Wedge Barrier	M50

“K” indicates the DOS certified barrier speed ratings’ maximum vehicle impact speed achieved when a vehicle traveling at a nominal speed is successfully arrested by the barrier from a perpendicular direction.

e.g., K12 = 50mph (80kph), K8 = 40mph (65kph), K4 = 30mph (48kph).

“M” indicates the Tested Vehicle (Medium-Duty Truck weighing 15,000 lbs.) successfully arrested by the barrier.

e.g., M50 = 50mph (80kph), M40 = 40mph (65kph), M30 = 30mph (48kph).



High Security Wedge Barricades

DOS K-Rated Barriers • ASTM M-Rated Barriers • Shallow and Deep Foundation Barriers

Delta provides High Security Wedge Barricades with a crash rating as high as K54 in widths up to 240 inches (6096 mm) and up to 39 inches high (1 M). Delta's line of in-ground wedge barricades range from K4/M30 to K12/M50 with penetration less than 1M (3.3 feet).

Lowered to allow passage of authorized vehicles, these security barricades are the first line of defense at critical facilities including embassies, nuclear facilities, military bases and corporate headquarters. Delta's high security barricades provide high speed operations, shallow foundations, and sleek designs that are aesthetically pleasing and extremely effective. With security systems built for high traffic locations requiring rapid emergency fast operation rates, Delta Scientific's counter-terrorism barricade systems meet and exceed governments' highest level requirements. Used by the U.S. Department of Defense, U.S. Military, and U.S. Department of State, these High Security Barriers set the industry standards and can be implemented at any location worldwide.

Delta's High Security Wedge Barricades are available in hydraulic and electric versions. For extreme

environments Delta offers galvanization or LINE-X coatings to help alleviate rust and corrosion. We can match any Pantone or RAL color necessary for your application. Contact a Delta Sales Representative today to see how these protection systems can help secure your facility.

Wedge Barricades Products

- DSC550
- HD300
- DSC501
- DSC2000
- DSC207S
- HD2055
- TT207S
- HD200



DSC550

Open Frame Wedge Barricade

M50 Crash Rated Barrier

Crash tested at both 10' and 16' lengths

Certified By: ASTM

Certification Level: M50/P1

Installation Design: Shallow Foundation



The new Delta DSC550 open frame barricade marks the latest accomplishment from Delta Scientific Corporation. The DSC550's shallow 24" foundation is ideal for applications where underground utilities, buried pipes and other obstructions may present a challenge. The open frame format provides a unique counter-balance design with no springs or other mechanical assists that need extra maintenance.

Crash tested to the newest, more stringent ASTM F2656-20 M50 standard, the DSC550 achieved a P1 rating with negative penetration. The DSC 550-16' TR-P41362 and DSC 550-10' TR-P42175 has been approved by the PDC for interpolation between the two tested lengths. With an EFO speed of 1.5 seconds for the electro-mechanical version and .75 seconds for the hydraulic version, you can be assured that the DSC550 will perform under a high duress situation.

Easy installation, high performance, and low maintenance coupled with the intuitive touch screen panel with data-logging and custom programming makes the Delta DSC550 the one to beat!

Crash Rating	Foundation Depth	Normal Operating Speed	Emergency Operating Speed	Height	Widths	Configurations
M50/P1	23.5"	3-5 Seconds	0.75 (H) - 1.5 (E) Seconds	41.5"	10', 12', 14', 16'	Hydraulic or Electric

Foundational Drawing

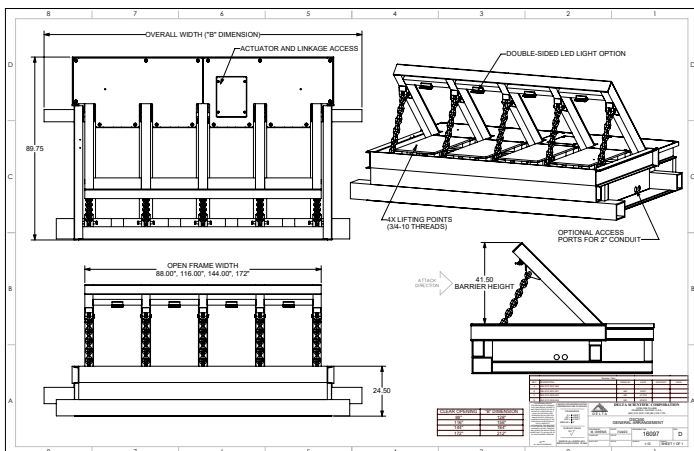

HD300 Wedge Barricade

M50 Crash Rated Barrier

Certified By: ASTM
Certification Level: M50/P1
Installation Design: Shallow Foundation



The HD300 barrier, available with either a fully electric or hydraulic control unit, will stop a 15,000 pound (66.7 Km) vehicle traveling 50 mph (80 kpm). Upon impact, the barrier remains in its foundation and the opening stays blocked, providing a multiple hit capability.

In its M50 crash test, the HD300 completely disabled the test vehicle, causing severe damage to the occupant department and power train. The maximum penetration recorded was an outstanding -1.8 m on the passenger's side. The P1 penetration rating was given because the penetration beyond the protected side of the barrier was less than 1.0 m at the lower leading edge of the test vehicle's cargo bed.

With its 24-inch (61 cm) shallow foundation and aesthetic design, the HD300 obviates the concerns of interference with buried pipes, power lines and fiber optic communication lines. The shallow foundation also reduces installation complexity, time, materials and corresponding costs. The HD300 is perfect for high water table locations and areas with corrosive soils. It provides low maintenance as all components are accessible from the sides or top of the barrier.

Crash Rating	Foundation Depth	Normal Operating Speed	Emergency Operating Speed	Height	Widths	Configurations
M50/P1	24"	3-5 Seconds	1.5 Seconds	39.4"	9' - 16'	Hydraulic or Electric

Foundational Drawing

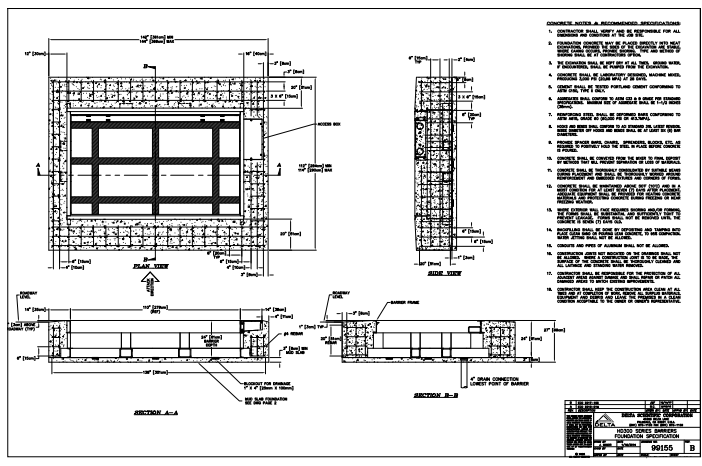

DSC501

Wedge Barricade

K12/K54 Crash Rated Barrier

Certified By: U.S. Department of State
Certification Level: K12/L3 (Certified up to K54)
Installation Design: Shallow Foundation Barrier



This high security barricade was designed for the U.S. Navy and has also been selected for use at U.S. Embassies. Set in a foundation only 18 inches (46 cm) deep, the Delta DSC501 is able to survive and operate after a 1.2 million foot pound impact. Upon extracting the truck after its crash test, the barricade was fully functional and performed a resounding 27,000 cycles with no wear!

With its shallow foundation and aesthetic design, it is a major breakthrough in high duty, anti-terrorist barricades. It obviates the concerns of interference with buried pipes, power lines and fiber optic communication lines. The shallow foundation also reduces installation complexity, time, materials and corresponding costs.

The DSC501 is suitable for high water table locations and areas with corrosive soils. Front face warning lights warn drivers that the barricade is in the “up” position. There is also an open area on the front for signage. Diagonal yellow and white stripes are standard and optional colors and graphics are available. The open channel construction even lets you specify hot dip galvanizing.

Crash Rating	Foundation Depth	Normal Operating Speed	Emergency Operating Speed	Height	Widths	Configurations
K12/L3	18"	3-5 Seconds	1.5 Seconds	39.4"	9' - 16'	Hydraulic

Foundational Drawing

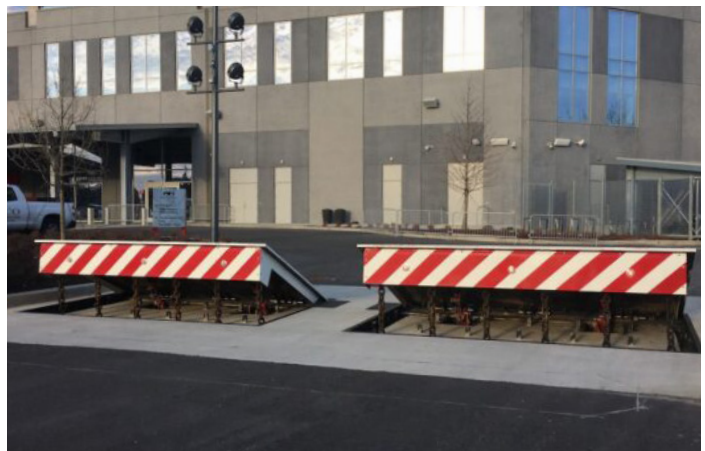
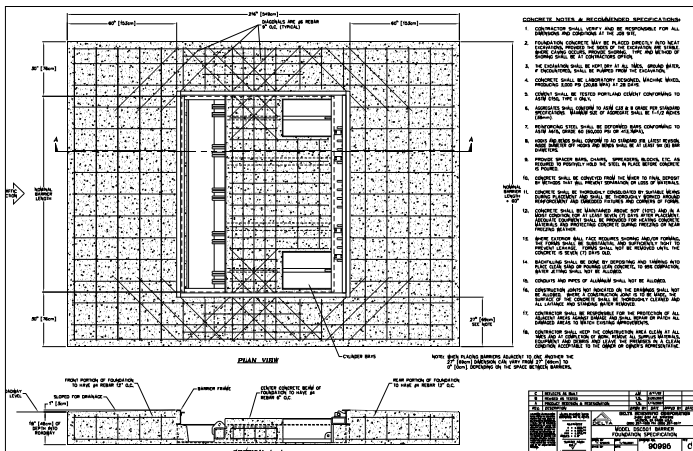

DSC2000

Modular Wedge Barricade

K12 Rated Barrier

Certified By: U.S. Department of State
Certification Level: K12/L3
Installation Design: Extremely Shallow Foundation

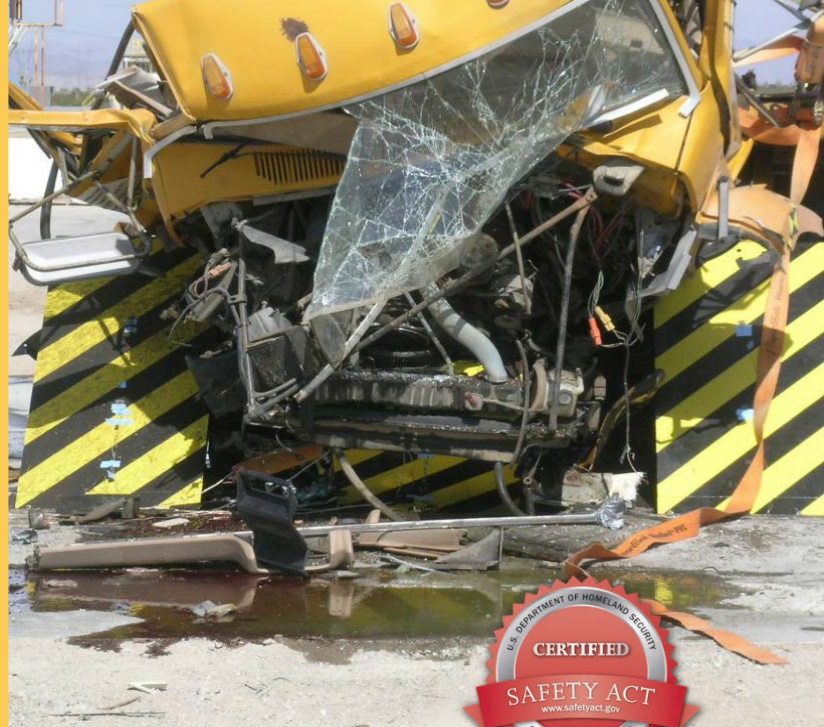

Because each module weighs only 1100 pounds (500 kg) and is easy to install, the DSC2000 barricade is perfect for remote locations and developing country installations. It fits in a small shipping package or air cargo container for convenient air transport. Modules can even be carried in the back of a pick-up truck.

With its extremely shallow foundation and aesthetic design, the DSC2000 is a major breakthrough in high duty, anti-terrorist barricades. It obviates the concerns of interference with buried pipes, power lines and fiber optic communication lines. The DSC2000 is perfect for high water table locations and areas with corrosive soils. The ten-inch shallow foundation also reduces installation complexity, time, materials and corresponding costs.

Delta's fastest, smallest and shallowest foundation barricade was created especially for high speed applications and ease of installation. It is K12 crash certified with no penetration, meaning it will stop a 15,000 pound (66.7 kN) vehicle traveling 50 mph (80 kph) dead in its tracks.

Crash Rating	Foundation Depth	Normal Operating Speed	Emergency Operating Speed	Height	Widths	Configurations
K12/L3	11"	3-5 Seconds	0.5 Seconds	36"	Modular 9' - 36'	Hydraulic

Foundational Drawing

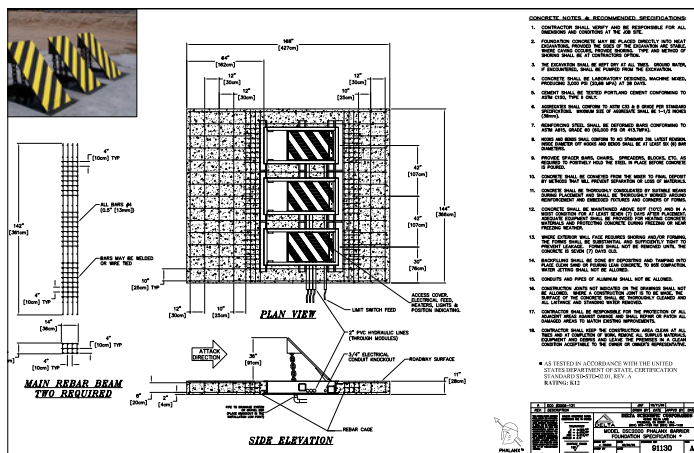

DSC207S

Wedge Barricade

M50 Crash Rated Barrier

Certified By: ASTM
Certification Level: M50/P1
Installation Design: Shallow Foundation Barricade



The new Embassy barricade is a fully enclosed, shallow foundation wedge barricade with a covered front and sides. In a full scale crash test conducted by an independent test lab, the DSC207s met the criteria for an M50/K12 rating. A 15,000 pound (6800 kg) truck impacting at 50 mph (80 km/h) was stopped dead in its tracks with zero penetration and caused no foundation damage. It features a small footprint, a new programmable drive system, and serviceable apparatus.

The new Embassy high security barricade provides foundation space in which maintenance personnel can easily work. There is space for heaters and sump pumps. Access is available from either the top plate or front. The barricade can also be galvanized. Its small footprint increases the numbers of locations in which it can be used. Available with Delta's new programmable drive system (PDS), the barricade can be electronically powered with an internal limit switch and multiple voltage input. The motor speed control can be programmed to control the barricade so that it operates quickly at first but, at the end of the stroke, slows down so that it does not slam, eliminating wear and noise. It is operated with touch screen control via hardwire, networked, or fiber optics.

Crash Rating	Foundation Depth	Normal Operating Speed	Emergency Operating Speed	Height	Widths	Configurations
M50/P1	30"	3-5 Seconds	1.5 Seconds	39.5"	9' - 16'	Hydraulic

Foundational Drawing

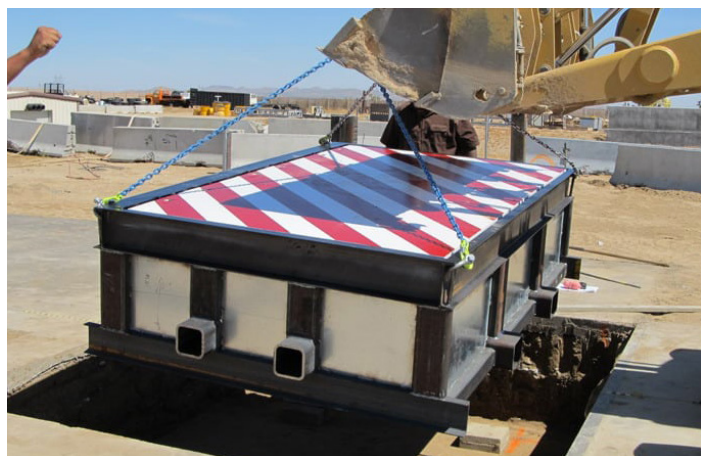
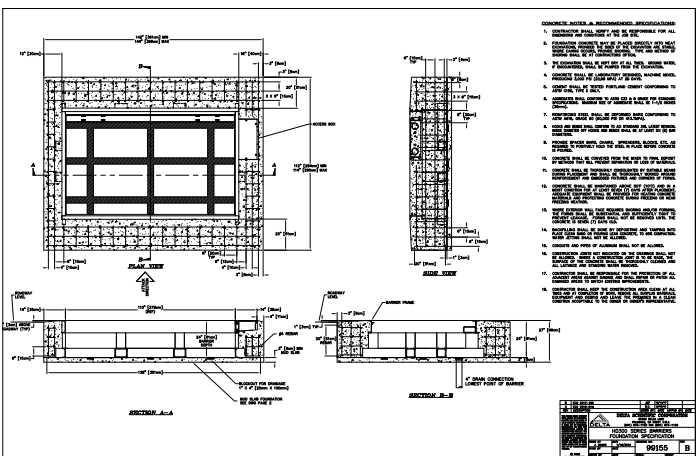

TT207S

Wedge Barricade

K12 Crash Rated Barrier

Certified By: U.S Department of State
Certification Level: K12/L3
Installation Design: Deep Foundation



The TT207S has been a staple in the crash rated wedge barrier space for more than four decades. The K12 rated TT207S wedge barrier is ideal for confined roadways, or roadways with close building proximity, thanks to its deep foundation design and small foundational footprint. This barrier has a robust, closed face design that is effective at preventing the buildup of sand, snow, or debris inside the barrier foundation.

The TT207S is available in widths from nine feet all the way up to twenty feet. Thanks to Delta's powerful hydraulic power units, multiple TT207S barriers in close proximity can be powered by the same unit. Versatility, serviceability, and stopping power have made the TT207S a favorite for high security facilities overseas and at home.

Crash Rating	Foundation Depth	Normal Operating Speed	Emergency Operating Speed	Height	Widths	Configurations
K12/L3	52.5"	3-5 Seconds	2.0 Seconds	38.5"	9' - 16'	Hydraulic

General Arrangement & Foundational Drawing

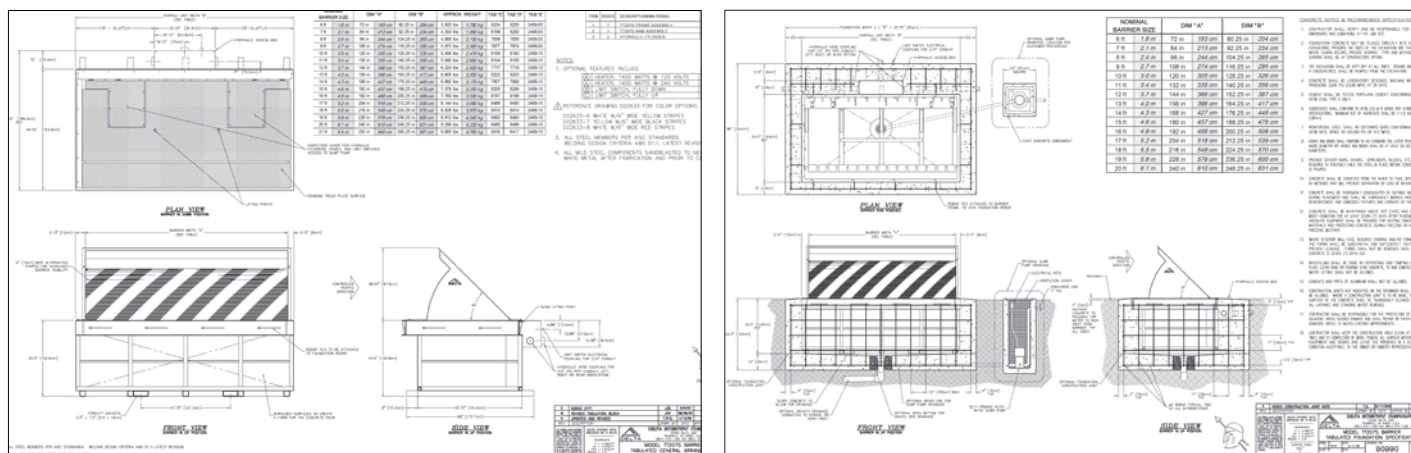

HD200

Wedge Barricade

M30 Crash Rated Barrier

Certified By: ASTM

Certification Level: M30/P1

Installation Design: Shallow Foundation



The breakthrough HD200, was built for high traffic locations requiring rapid emergency fast operation (EFO) rates and open/close cycles. With a 0.63 second EFO and a 2-5 second normal operation rate, the HD200 is the fastest operating standard vehicle barrier in the market. In addition, it features a crash rating of ASTM M30/P1. That means it will bring to a full stop a 7.5 ton (6803.9 kg) medium duty truck traveling 30 mph (48.3 kph) in less than 3.3 feet (1 meter). In fact, the truck rebound after impacting the barrier was an incredible 11.5 feet.

With a 24-inch (61 cm) shallow foundation and fully enclosed, flush mount design, the HD200 Security Barricade obviates the concerns of interference with buried pipes, power lines and fiber optic communication lines in urban applications. The shallow foundation also reduces installation complexity, time, materials and corresponding costs. The HD200 is perfect for high water table locations and areas with corrosive soils. It provides low maintenance as its totally enclosed face is easily removed for access. The HD200 barrier also features a full range of diagnostic indicators for early detection of any difficulties.

Crash Rating	Foundation Depth	Normal Operating Speed	Emergency Operating Speed	Height	Widths	Configurations
M30/P1	24"	3-5 Seconds	1.5 Seconds	30"	9' - 16'	Hydraulic

Foundational Drawing

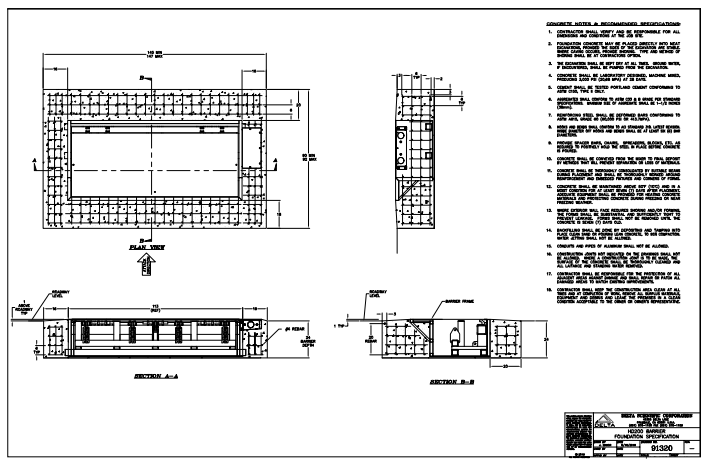



Crash Rated Beam Barricades

Delta's crash rated beams are available in hydraulic, electric, and manually operated models. Our crash beams carry ratings from M30 to M50 with penetration levels up to P1 (3' or less). Multiple configurations include vertical and horizontal actuation with lengths from 10' to 30' (3m to 9m). Adjustable speed options are available with the ability to provide an Emergency Fast Operation of less than 2 seconds if required.

Beam barriers are the perfect solution for ingress and egress applications where you require good vehicle throughput without having to disturb the roadway during installation. The buttresses sit on either side of the road with only the beam perched above it. They are ideal solution to deter theft from parking lots. Delta's beams are used at government facilities, military bases, airports, public and private entities and many automotive sales facilities including all of CarMax's properties. Delta's beam barricades can be trusted to provide the reliability and stopping power known from the Delta brand. Contact a Delta Scientific Sales Representative to see how these protection systems can help secure your facility.

Beam Barricades Products

- DSC7000
- DSC7500
- DSC7090
- TT212
- TT212E
- TT212EC
- TT218
- TT218E
- TT218EC

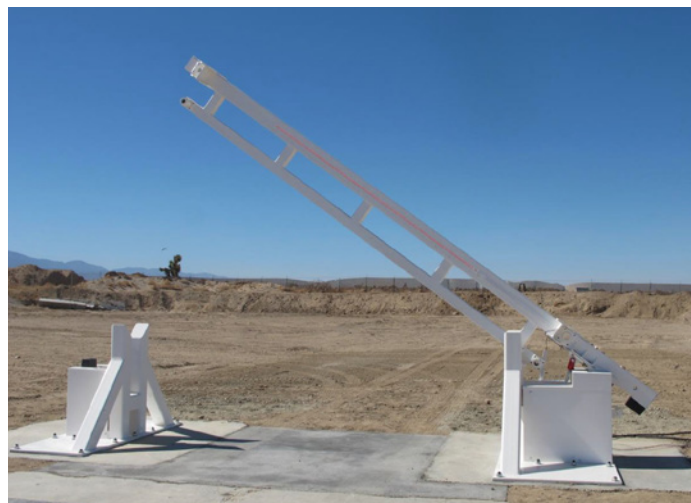

DSC7000

Vertical Rising Beam Barricade

K12 Crash Rated Barrier

Certified By: U.S. Department of State
 Certification Level: K12/L3
 Installation Design: Shallow Foundation



Crash Rated Beam Barricades

The DSC7000 crash rated beam barricade is used worldwide at locations where wide roadways need to be secured from attacking vehicles. It provides protection between 12- to 20-foot wide with options to 30 feet (3.7 to 9.2 m). The 725-pound beam of the vertical lift barricade stops a 15,000-pound (66.7 kN) vehicle traveling 50 mph (80 kph) dead in its tracks, equivalent to 1.2-million foot-pounds of kinetic energy.

It meets the K12 crash certification standard set by the United States Department of State.

The DSC7000(H) operates from a standalone Hydraulic Pumping Unit that can be upgraded to accommodate beam lengths up to 30'. The HPU can be powered from a local single or three-phase power source. Alternatively, the DSC7000(H) can be powered and operated automatically from a Battery Powered HPU, which can be maintained at operating power level by a solar array or by low power alternative sources.

Crash Rating	Foundation Depth	Normal Operating Speed	Emergency Operating Speed	Height	Widths	Configurations
K12/L3	36"	1.5 feet per second - Adjustable	2.0 Seconds	33"	12' - 30'	Hydraulic, Electric, Manual

General Arrangement

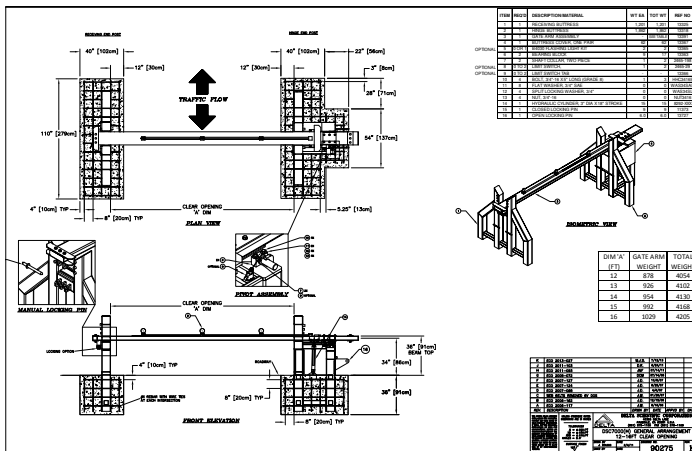

DSC7500

Horizontal Swinging Beam Barricade

K12 Crash Rated Barrier

Certified By: U.S. Department of State, PAS 68: 2007

Certification Level: K12/L3

Installation Design: Shallow Foundation



Crash Rated Beam Barricades

The DSC7500 swing beam barricade is designed to close off one or two lanes of a roadway and provide counter terrorist level protection against vehicle attack. The barricade stops a 15,000-pound (66.7 kN) vehicle traveling 50 mph (80 kph) with zero penetration, equivalent to 1.2-million foot-pounds of kinetic energy. It meets the K12 crash certification standard set by the United States Department of State.

The DSC7500 is supplied as an easy to use manual gate or powered with full automation features. Other versions of the DSC7500 Series include a full swing gate with anti-climb features that can replace existing non-rated swing gates.

A cantilevered sliding gate with the DSC7000 series crash beam is also available with the full crash rating. The DSC7500 has been tested to the United Kingdom BSI Standard PAS:68 2007 Crash Test. 7.5 Tonne EU truck at 80 kph. Zero penetration. The beam held and was wedged in place. Delta Scientific certifies the The DSC7000 beam has been tested to the United Kingdom BSI Standard PAS:68 2007 in the DSC7500 configuration.

Crash Rating	Foundation Depth	Normal Operating Speed	Emergency Operating Speed	Height	Widths	Configurations
K12/L3	36"	1.5 feet per second - Adjustable	N/A	33"	12' - 30'	Hydraulic, Electric, Manual

Foundational Drawing

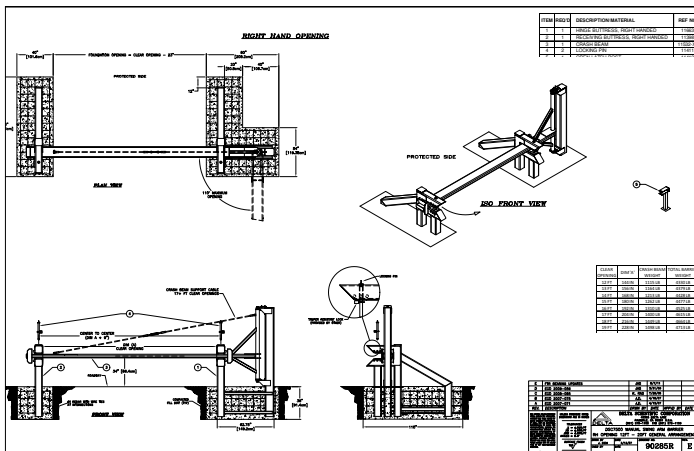

DSC7090

Vertical Rising Beam Barricade

M30 Crash Rated Barrier

Certified By: ASTM

Certification Level: M30/P1

Installation Design: Bolt Down Shallow Foundation



Raising in only five seconds and lowering in merely two seconds yields a fast cycle rate of over 100 vehicles in and out per hour, making the DSC7090 ideal for higher traffic and population locations. The DSC7090 is used when wide roadways need to be secured from attacking vehicles and in larger parking areas where security systems are needed to deter theft.

The DSC7090 is crash tested to an ASTM M30/P1 rating. That means it will stop a 15,000 pound (6800 kg) truck going 30 mph (50 kph) with negative 6.3 feet (1.9 m) of penetration. The dual beam design provides coverage of 12 to 24 feet (3.7 to 7.3 m) of roadway with a full 90 degree opening. This prevents both large and small vehicles from breaching the security perimeter.

The bolt-down design of the DSC7090 provides easy installation now and, if needed, for replacement in the future.

Crash Rating	Foundation Depth	Normal Operating Speed	Emergency Operating Speed	Height	Widths	Configurations
M30/P1	24"	2.5 feet per second - Adjustable	2.0 Seconds	20" Bottom, 33" Top	12' - 24'	Hydraulic, Electric, Manual

Foundational Drawing

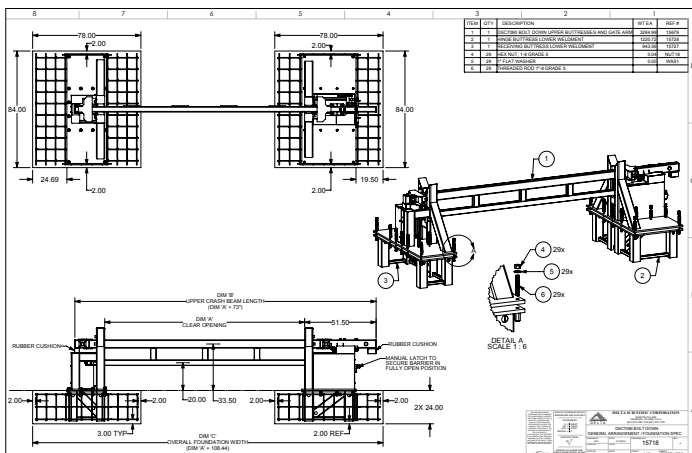

TT212, TT212E, TT212EC

Vertical Rising Beam Barricades

K1, K4 Crash Rated Barriers

Certified By: U.S. Department of State & Finite Analysis

Certification Level: K1, K4

Installation Design: Deep Foundation



Crash Rated Beam Barricades

The TT212 Beam Barricades is used at government facilities, embassies and automotive sales facilities. When CarMax, the Auto Superstore® and the nation's leading specialty retailer of used cars, needed a low maintenance system that would deter theft from their lots and integrate with their present security system, they chose Delta Scientific's beam barricades.

The high-strength wire rope of the TT212 will stop a non-armored or non-tracked vehicle weighing 6,000 pounds at 40 mph (26,7 KN at 64 kph). Beams are raised to allow passage of authorized vehicles. Clear opening ranges from 10.5 to 24 feet (3,200 mm to 7,315 mm) are available to allow passage of almost every type of vehicle.

TT212	Crash Rating	Foundation Depth	Normal Operating Speed	Emergency Operating Speed	Height	Widths	Configurations
	K1/L3	48"	1.5 feet per second - Adjustable	N/A	33"	12' - 24'	Hydraulic, Electric, Manual

TT212E	Crash Rating	Foundation Depth	Normal Operating Speed	Emergency Operating Speed	Height	Widths	Configurations
	K4 Engineered	48"	1.5 feet per second - Adjustable	N/A	33"	12' - 24'	Hydraulic, Electric, Manual

TT212EC	Crash Rating	Foundation Depth	Normal Operating Speed	Emergency Operating Speed	Height	Widths	Configurations
	K4/L2	48"	1.5 feet per second - Adjustable	N/A	33"	12' - 20'	Hydraulic, Electric, Manual

TT218, TT218E, TT218EC

Horizontal Swinging Beam Barricades

K1, K4 Crash Rated Barriers

Certified By: U.S. Department of State & Finite Analysis

Certification Level: K1, K4

Installation Design: Deep Foundation



The TT218 Beam Barricade Swing Gate is used at locations where vertical lifts are impractical. It provides clear opening ranges from 10.5 to 24 feet (3,200 mm to 7,315 mm.) Operation is manual.

The TT218 series beams are perfect for locations where you don't have a lot of vehicle throughput but you still need the peace of mind protection that a crash rated product from Delta Scientific offers. These beams are also ideal for remote locations that are out of the way.

TT218	Crash Rating	Foundation Depth	Normal Operating Speed	Emergency Operating Speed	Height	Widths	Configurations
	K1/L3	48"	1.5 feet per second - Adjustable	N/A	33"	12' - 24'	Hydraulic, Electric, Manual

TT218E	Crash Rating	Foundation Depth	Normal Operating Speed	Emergency Operating Speed	Height	Widths	Configurations
	K4 Engineered	48"	1.5 feet per second - Adjustable	N/A	33"	12' - 24'	Hydraulic, Electric, Manual

TT218EC	Crash Rating	Foundation Depth	Normal Operating Speed	Emergency Operating Speed	Height	Widths	Configurations
	K4/L2	48"	1.5 feet per second - Adjustable	N/A	33"	12' - 20'	Hydraulic, Electric, Manual



High Security Bollards

Delta's bollard product line ranges from K4/M30 to K12/M50 to protect under the most extreme circumstances. All Delta vehicle access control equipment meets or exceeds U.S. Department of State, ASTM and Department of Defense certifications. Such strength is important whether you're planning to secure a military base, warehouse or even a sidewalk to protect pedestrians.

Security Bollards are aesthetically pleasing and allow pedestrians to move between bollards in non-roadway applications. They are available with a variety of decorative covers and the architect may design their own cast covers to reflect architectural details of the facility. You can specify cast sleeves of aluminum, fiberglass, or brushed stainless steel, all of which slip right over the crash tube. Crash Rated Bollards may be fitted with an internal warning light for increased visibility and engineered to suit high traffic volumes. Delta has a product line of shallow foundation bollards with excavation as little as 14". These come in fixed and removable options and are rated up to K12. Delta's high security bollard systems operate individually or in groups of up to

ten and are used for intermediate to high level security applications. Hydraulic and pneumatic, electromechanical, and manual versions can be operated by a variety of control systems.

Bollard Products

- DSC720-1M
- DSC720
- DSC701
- DSC800
- DSC635
- DSC633
- DSC600
- DSC650
- DSC305



DSC720-1M

High Security Bollard

Multiple Configurations

M50 Decorative Crash Rated Bollard

Certified By: ASTM

Certification Level: M50/P1

Installation Design: Deep Foundation



Delta Scientific's new DSC720-1M security bollards, created to stop taller trucks such as those found in Europe and the Middle East from tumbling over anti-terrorist crash-proof bollards, stopped a 15,000 pound (66.7 Km) flatbed truck impacting at 50 miles per hour (80 kph) with only a 0.5 meter penetration of the vehicle, creating an M50, P1 ASTM rating. The bollards caused severe damage to the engine and drive train. "This is the type of stopping power customers want for ASTM 50 and K-12 rated bollards," emphasizes David Dickinson, Delta Scientific senior vice president.

The DSC720-1M's controls feature touch screen panels, data logging and Cat 5 cable connections with options of control via a closed network, the Internet, fiber optic or remote operation. Decorative castings and brushed stainless steel sleeves are standard options.

Crash Rating	Foundation Depth	Normal Operating Speed	Emergency Operating Speed	Height	Widths	Configurations
M50/P1	72"	3-5 Seconds	2.0 Seconds	39"	Unlimited	Hydraulic, Pneumatic, Manual, Fixed

General Arrangement

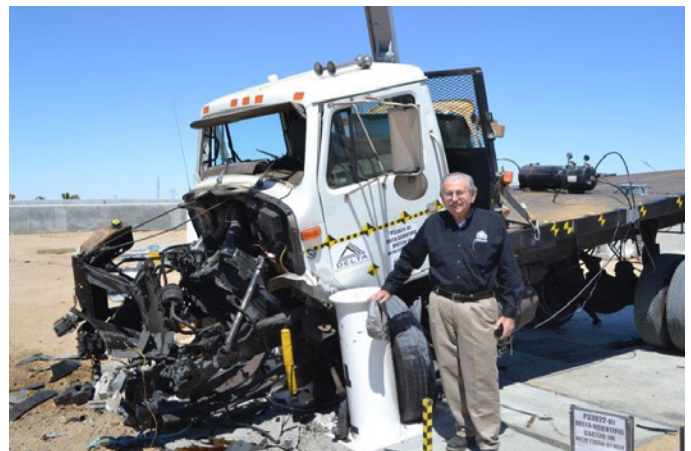
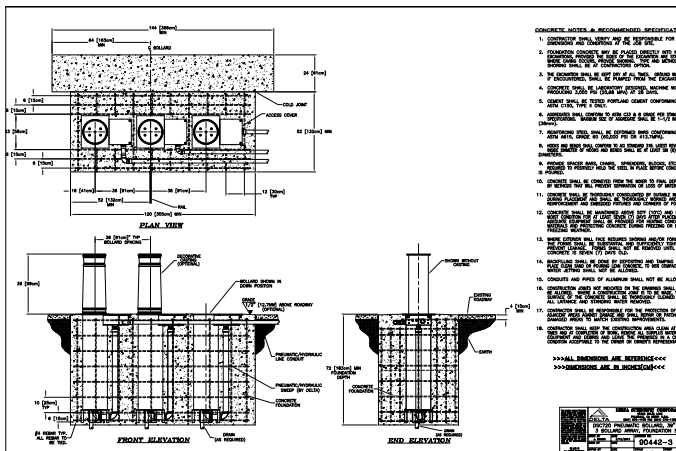

DSC720

High Security Bollard

Multiple Configurations

K12 Decorative Crash Rated Bollard

Certified By: U.S. Department of State, PAS 68: 2007

Certification Level: K12/L3

Installation Design: Deep Foundation



The DSC720 is Delta's highest crash rated bollard tested with a 15,000 lb vehicle at 50 mph and achieving K-12 bollards crash rating. This high security bollard will stop and destroy much larger vehicles than those tested at very high velocities. Applications include Federal and DOD facilities, embassies and high profile, high-risk clients.

The DSC720 high security barricade bollards are 35 inches (89 CM) tall and 15.1 inches wide without the casting. The DSC720 series is available as painted steel tube or supplied with a brushed stainless steel sleeve or decorative aluminum castings using Delta's standard or custom design for a specific project.

The DSC720 bollards are available with Hydraulic Power (HPU), Delta's All Weather Pneumatic, Electromechanical, Manual and as Fixed Posts all with matching sleeves or covers. Consult Delta's sales department for application recommendations.

Crash Rating	Foundation Depth	Normal Operating Speed	Emergency Operating Speed	Height	Widths	Configurations
K12/L3	68"	3-5 Seconds	2.0 Seconds	36"	Unlimited	Hydraulic, Pneumatic, Manual, Fixed

General Arrangement

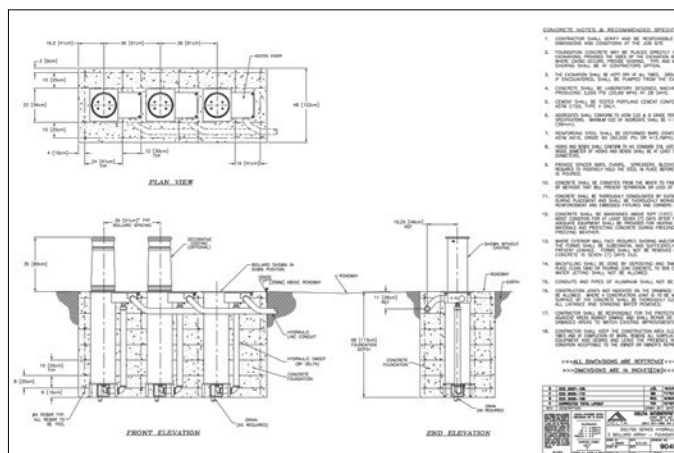

DSC701

High Security Bollard Multiple Configurations

K8 Decorative Crash Rated Bollard

Certified By: U.S. Department of State

Certification Level: K8/L2

Installation Design: Deep Foundation



The DSC701 high security bollards can be a hydraulic, pneumatic, manual operation or fixed post bollard. Its height is 35 inches and diameter is between 12.75 inches. Its speed of operation can be adjusted from 3 to 10 seconds. Some of its current applications include protecting Federal buildings and cargo depots.

These security bollards can look utilitarian or elegant as the application requires, yet come are crash rated K-8 Bollards and L2 Bollards. The bollard can be used with or without a decorative aluminum casting. The castings can be powder-coated and available in a variety of styles.

The architect can design a location specific version to match the architecture of the facility including emblems or logos.

Crash Rating	Foundation Depth	Normal Operating Speed	Emergency Operating Speed	Height	Widths	Configurations
K8/L3	68"	3-5 Seconds	2.0 Seconds	36"	Unlimited	Hydraulic, Pneumatic, Manual, Fixed

Foundational Drawing

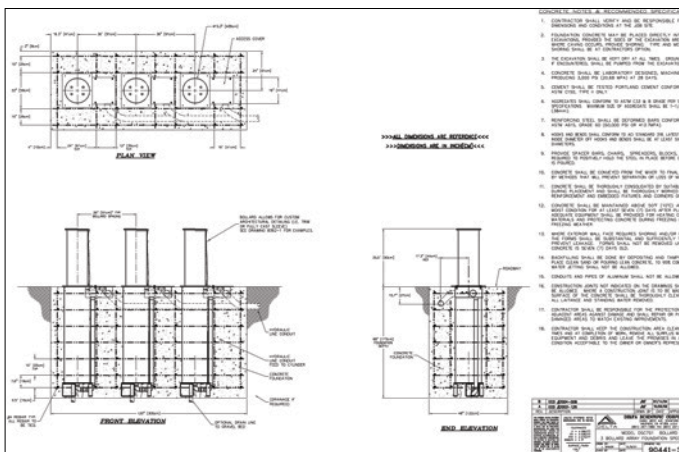

DSC800

High Security Bollard

Multiple Configurations

K4 Decorative Crash Rated Bollard

Certified By: U.S. Department of State
 Certification Level: K4/L3
 Installation Design: Deep Foundation



The DSC800 crash rated bollards can be a hydraulic, pneumatic, manual operation or fixed post bollard. Its height is 30 inches and its diameter is 6.63 inches. Applications include lower threat or low speed areas for Federal applications, residential, universities, walkways, cargo depots and rental car agencies. Retractable bollard speed of operation can be adjusted from 3 to 10 seconds.

These high security bollards can look utilitarian or elegant, as the application requires. They can be used with or without a decorative aluminum casting. The castings can be powder-coated and available in a variety of styles.

The architect can design a location specific version to match the architecture of the facility including emblems or logos. Decorative bollards protect pedestrian walkways from errant vehicles while enhancing the aesthetics of the area.

Crash Rating	Foundation Depth	Normal Operating Speed	Emergency Operating Speed	Height	Widths	Configurations
K4/L3	48"	3-5 Seconds	2.0 Seconds	30"	Unlimited	Hydraulic, Pneumatic, Manual, Fixed

Foundational Drawing

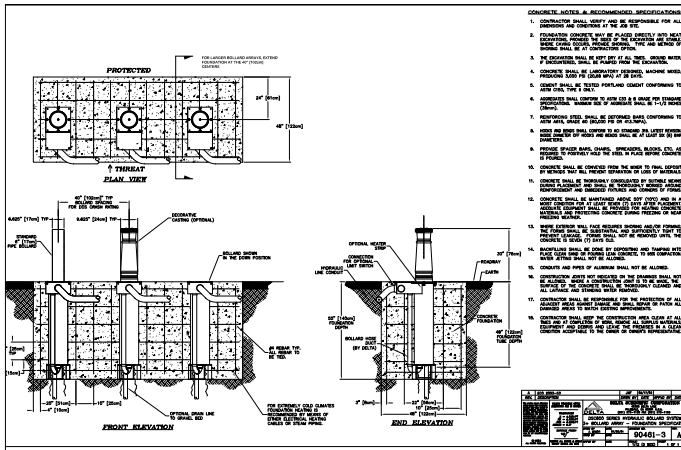

DSC635

High Security Single Shallow Foundation Bollard

M50 Decorative Crash Rated Fixed and Removable Bollard

Certified By: ASTM

Certification Level: M50/P1 Static, M50/P2 Dynamic

Installation Design: Single Shallow Foundation



Delta Scientific's new DSC635 shallow foundation single bollard has been successfully tested to ASTM F2656-20 M50/P1 standards. Designed for applications where underground utilities and space limitations pose a problem, the DSC635 is the perfect solution.

The DSC635 is a single shallow foundation bollard design that stopped and destroyed a 15,000 pound test truck with less than two feet of static penetration and 6.14 feet of dynamic penetration. The simulated bomb load remained intact and contained on the truck bed. The test vehicle weighed 15,000 pounds and was traveling over 50 miles per hour. The DSC635 bollard has a height of 44 inches and a diameter of 15.75 inches with a cover. Delta's bollards can be furnished with an array of decorative covers to enhance the look and match the aesthetic of the surrounding structures.

Crash Rating	Foundation Depth	Normal Operating Speed	Emergency Operating Speed	Height	Widths	Configurations
ASTM M50	24"	N/A	N/A	44"	Unlimited	Fixed, Removable

General Arrangement

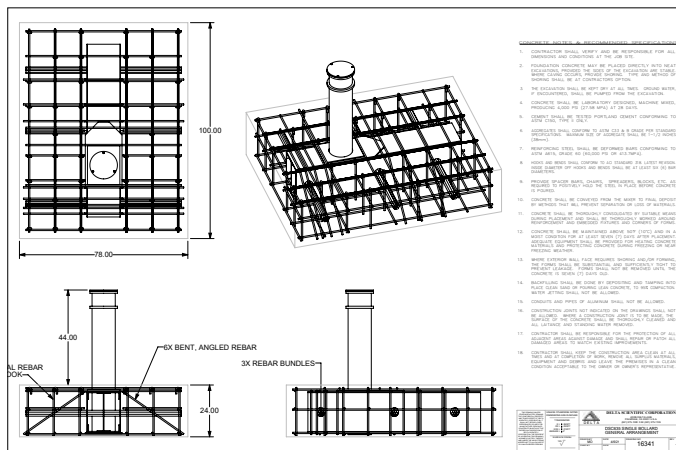

DSC633

High Security Single Shallow Foundation Bollard

M30 Decorative Crash Rated Fixed and Removable Bollard

Certified By: ASTM

Certification Level: M30/P1

Installation Design: Single Shallow Foundation



Delta Scientific's new DSC633 shallow foundation bollard single bollard has been successfully tested to ASTM F2656-20 M30/P1 standards. Designed for applications where underground utilities and space limitations pose a problem, the DSC633 is the perfect solution.

The DSC633 is a single shallow foundation bollard design that stopped and destroyed a 15,000 pound test truck with an amazing -3.63 feet of dynamic penetration and -8.82 feet of static penetration. The simulated bomb load remained intact and contained on the truck bed. The test vehicle weighed 15,000 pounds and was traveling over 30 miles per hour. The DSC633 bollard has a height of 44 inches and a diameter of 13.75 inches with a cover. Delta's bollards can be furnished with an array of decorative covers to enhance the look and match the aesthetic of the surrounding structures.

Crash Rating	Foundation Depth	Normal Operating Speed	Emergency Operating Speed	Height	Widths	Configurations
ASTM M30	24"	N/A	N/A	44"	Unlimited	Fixed, Removable

General Arrangement

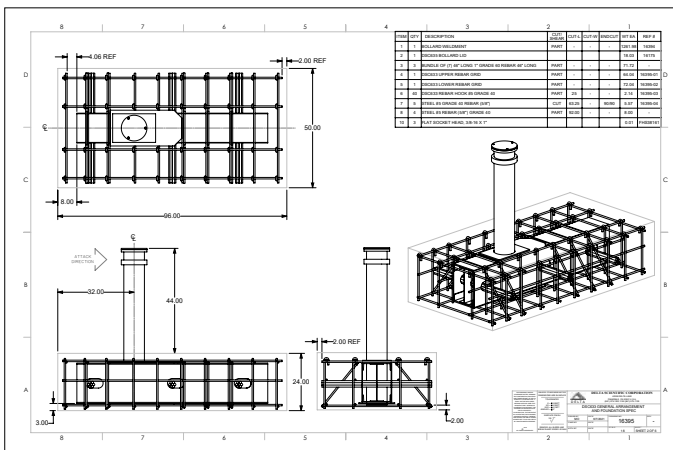

DSC600

High Security Shallow Foundation Bollard

K12 Decorative Crash Rated Fixed and Removable Bollard

Certified By: U.S. Department of State

Certification Level: K12/L3

Installation Design: Shallow Foundation



Delta Scientific's DSC600 Shallow Foundation Bollards protect approaches to buildings, drop-off and passenger loading areas at transportation hubs, storefronts, sports arenas, office buildings and other presently unprotected locations where vehicle bombers and errant drivers have no obstacles.

With the DSC600 crash rated bollard modules, those facilities surrounded by streets, abutting sidewalks and set back on lawns, such as many state capitals, other government structures, stadiums, theaters, and commercial buildings, can now be effectively protected. With a foundation only 14 inches (35.5 cm) deep versus the four feet (1.2 m) typically required, Delta's DSC600 Shallow Foundation High Security Bollards can be installed within sidewalks, on top of concrete deck truss bridges, or in planters.

Crash Rating	Foundation Depth	Normal Operating Speed	Emergency Operating Speed	Height	Widths	Configurations
K12/L3	14"	N/A	N/A	44"	Unlimited	Fixed, Removable

General Arrangement

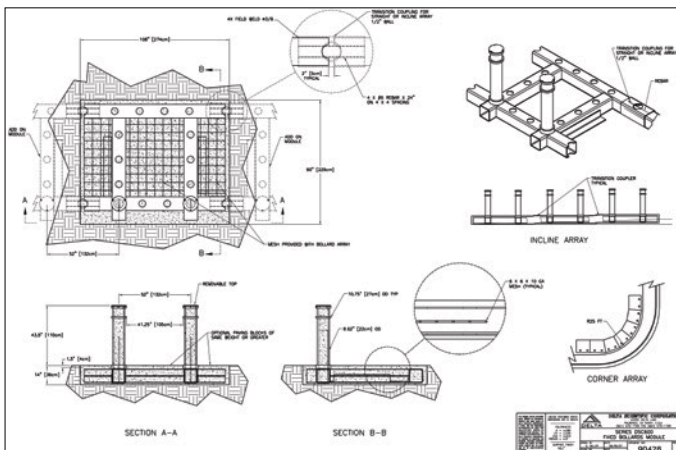

High Security Bollards

DSC650

Medium Security Shallow Foundation Bollard

PU50 Decorative Crash Rated Fixed and Removable Bollard

Certified By: ASTM

Certification Level: PU50

Installation Design: Shallow Foundation



Delta Scientific's DSC650 Shallow Foundation High Security Bollard arrays are a down-scaled version of the DSC600 arrays. The DSC650 fixed bollard modules will stop a 5000-pound (2300 kg) vehicle going 50 mph (80 kph) while the DSC600 array stops a 15,000-pound (6900 kg) vehicle going the same speed.

The DSC650 module functions as a standalone module or part of an extended array on shallow substrates, including those that are not level or have turns. Two modules are available. The first model provides a choice of having either one or two of the bollards being removable, to let vehicles through, and lockable so they cannot be removed by unauthorized people. The second is a corner module of 90 degrees featuring three bollards. Both versions are available with Delta standard or custom decorative cast aluminum or fiberglass coverings.

Crash Rating	Foundation Depth	Normal Operating Speed	Emergency Operating Speed	Height	Widths	Configurations
PU50	12"	N/A	N/A	30"	Unlimited	Fixed, Removable

Foundational Drawing

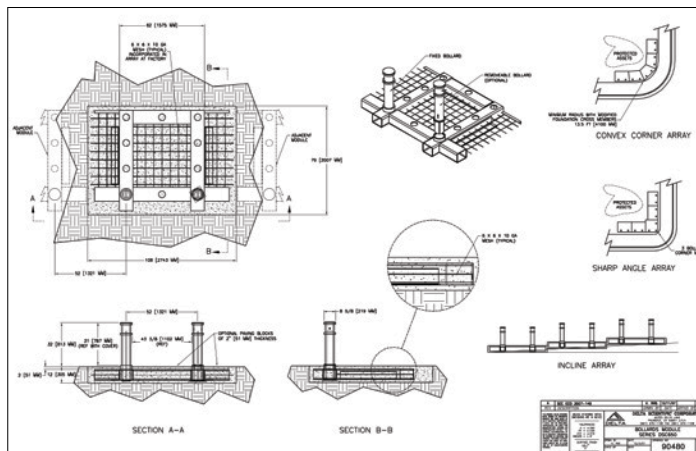

DSC305

Medium Security Chrome Bollard

K1 Engineered Decorative
Crash Rated Bollard

Certified By: Engineered - Finite Analysis
Certification Level: K1
Installation Design: Deep Foundation



The Model DSC305-PE Bollard System ("DSC305") is designed to provide positive control of automobiles and trucks into and out of restricted areas.

Precision steel bollards raised and lowered by a quiet pneumatic source are used as a primary bulwark against unauthorized or wayward vehicles and can stop aggravated or accidental vehicle attacks.

The DSC305 was designed for medium threat security applications and is engineered to stop and destroy light duty trucks and high speed passenger cars. The DSC305 can be a standalone traffic controller for a single lane traffic-way, or it can be arrayed to control multiple lanes of bi-directional traffic.

Crash Rating	Foundation Depth	Normal Operating Speed	Emergency Operating Speed	Height	Widths	Configurations
K1 Engineered	45"	3-5 Seconds	2.0 Seconds	24"	Unlimited	Hydraulic, Pneumatic, Manual, Fixed

Foundational Drawing

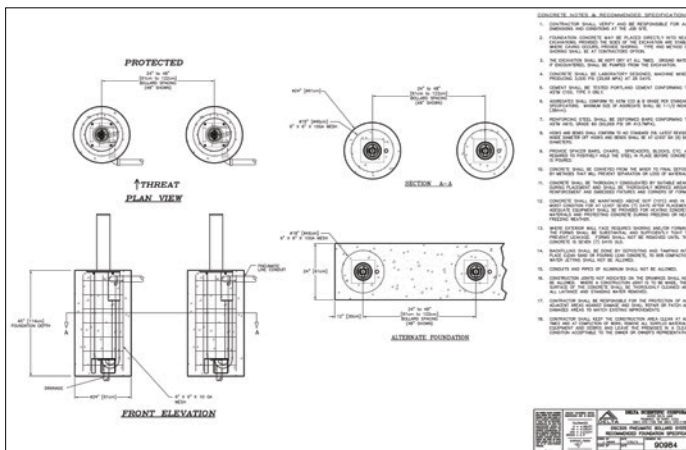



High Security Gates

From airports to embassies, from warehouses to depots, Delta Scientific's high security crash rated gates stop unauthorized pedestrians and vehicles from entering places that they don't belong. Delta designs and manufactures a full line of crash rated gates to protect and control perimeter entries. Some models operate without contact with the ground across the opening, one is a manually operated swing gate and others operate with rack and pinion drives across V-groove wheel ground tracks while incorporating IR safety beam and safety edges. Swing versions are also available.

Not only can these popular crash rated gates withstand impacts as high as a 15,000 lb (66.7 kN) vehicle striking at 50 MPH (80 KPH) and suffer no significant damage, but they also look good too. Architects and contractors can choose from sliding and swing crash-tested gates in 14 different decors – green landscaping, screen printed glass, steel screen, back-painted glass, laser cut steel in two versions, panelized colored acrylic, panelized stone, panelized concrete, cast stone, wood and stone, panelized wood and wood screen.

Delta's high security gates are powered by either electro-mechanical or hydraulic systems. Typical drive speeds are 60 ft (18.3 m) per minute, depending on electrical supply and gate length. Supplied Delta controls meet all requirements for control and safety.

Delta Scientific's high security crash gates are designed to stop all threats and afford maximum impact protection that is ideal for securing critical infrastructure locations and high risk areas. Perimeter entry control high security gates can be found at airports, power plants, embassies, military installations and government facilities.

Gate Products

- DSC288
- TT280
- TT300
- SC3000S
- SGC1000
- DSC8000

DSC288

High Security Sliding Gate

M50 Crash Rating

Certified By: ASTM

Certification Level: M50/P1

Installation Design: Tracked, Cantilevered or Swinging



For the first time, a high security (DOS K12/ASTM M50– no penetration) gate can now fully match the perimeter fence in materials ranging from wood, steel, mesh, glass, fence pickets or railings. Anti-climb, clear or opaque ballistic in fill are all available. The gate is guided from the rear side leaving out the front buttresses. This provides the architect and security engineer flexibility on the face treatment or in fill of the gate. The gate can be supplied as an open frame for field fitting or supplied completely assembled. The crash beam behind the gate stops the vehicle not the face.

The DSC288 features a shallow foundation of only 33.5 inches (85 cm) to avoid underground utility conflicts. It also significantly lowers the time and cost of installation. A typical installation can be completed in only three days. The DSC288 can be ordered as a tracked gate or a cantilevered (suspended) gate. It is available with a plug and play touchscreen control with intelligent monitoring and a programmable logic control. A positive latch pin secures the gate in the fully closed position and protects against mobs forcing the gate open.

Crash Rating	Foundation Depth	Normal Operating Speed	Emergency Operating Speed	Height	Widths	Configurations
M50/P1	35.5"	1.5 feet per second - Adjustable	N/A	108" Standard	9' - 30'	Electric or Hydraulic

General Arrangement

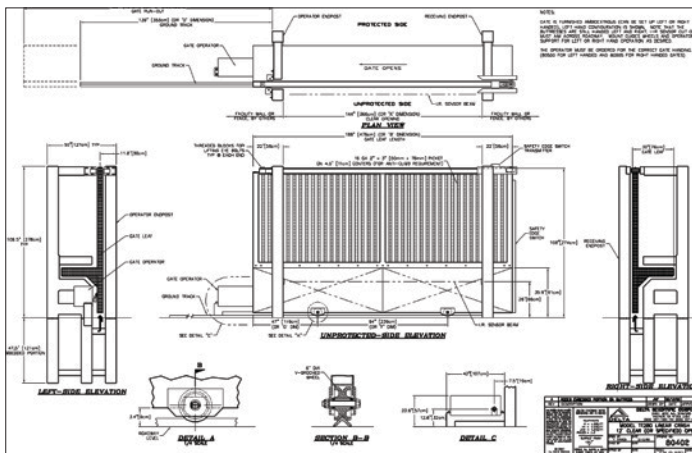

TT280

High Security Sliding Gate

K12 Crash Rating

Certified By: U.S. Department of State

Certification Level: K12/L3

Installation Design: Tracked, Cantilevered or Swinging



The TT280 Linear Crash Rated Gate will withstand the impact of a 15,000 lb vehicle striking the gate at 50 MPH, suffering no significant damage. The TT280 was created for the highest security applications such as embassies, government facilities and corporate headquarters.

The gate can be tailored to match the surrounding decor in a wide variety of architectural treatments.

Delta's sliding high security gates are all crash rated. One model, the TT280, pictured here, exceeds every known standard for crash worthiness. Some models operate without contact with the ground across the opening, one is a manually operated swing gate while others operate with rack and pinion drives across V-groove wheel ground tracks while incorporating IR safety beam and safety edges. Swing versions are also available. The clear openings range from 12 to 30 feet (3,657 mm to 9,144 mm). The standard height for all, except the swing gate, is 109 inches (2,769 mm).

Crash Rating	Foundation Depth	Normal Operating Speed	Emergency Operating Speed	Height	Widths	Configurations
K12/L3	53"	1.5 feet per second - Adjustable	N/A	108" Standard	9' - 30'	Electric or Hydraulic

Foundational Drawing

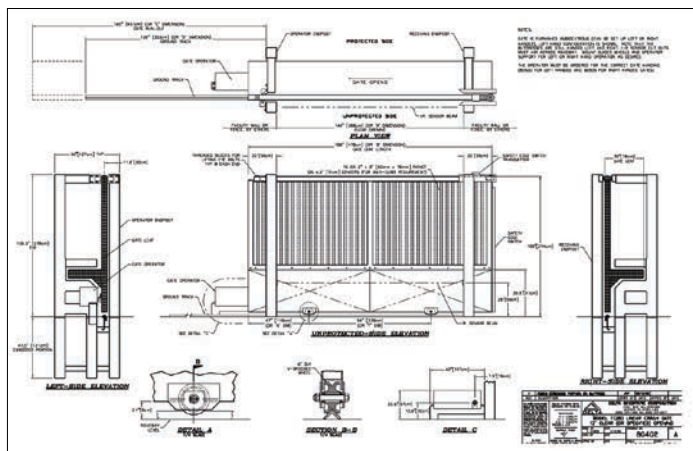

TT300 High Security Tracked Rolling Gate

K4 Crash Rated Gate

Certified By: Engineered Rated

Certification Level: K4

Installation Design: Tracked Gate



The Delta Scientific TT300 high security rolling pedestrian gate is ideal for installations that need rugged performance for large crowds and vehicle control. The drive mechanism is electro-mechanical or hydraulic, with the final drive via rack and pinion with V-groove wheels in sub-grade or at-grade ground tracks.

The gate can be tailored to match the surrounding decor in a wide variety of architectural treatments.

Delta Scientific is well known in the industry for custom applications. Our TT300S high security sliding gates can be customized to suit our clients' specific needs. Below, these anti-climb M30 crash rated gates, is a perfect example of how Delta can work with you and your team to develop the perfect application for your facility.

Crash Rating	Foundation Depth	Normal Operating Speed	Emergency Operating Speed	Height	Widths	Configurations
K4 Engineered	51.5"	1.5 feet per second - Adjustable	N/A	108" Standard	9' - 30'	Electric or Hydraulic

Foundational Drawing

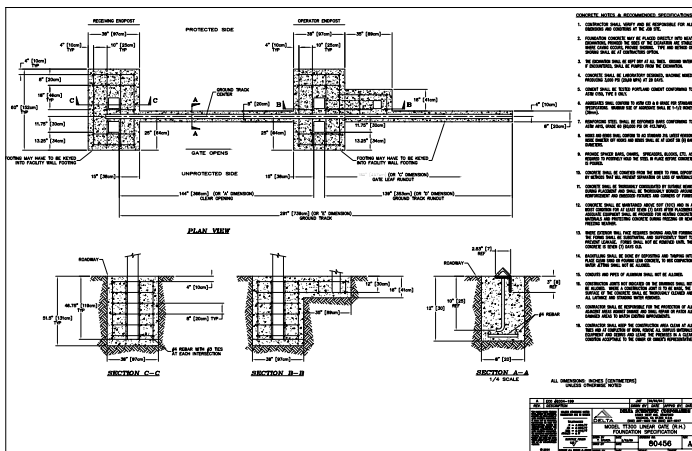

SC3000S

High Security Cantilevered Rolling Gate

K4 Crash Rated Gate

Certified By: Engineered Rated

Certification Level: K4

Installation Design: Cantilevered Gate



The cantilevered SC3000S sliding gate is ideal for locations that have ground interference and need the leaf of the gate suspended over the roadway. This rugged gate allows for railroad tracks or any other ground obstruction to easily pass underneath the gate leaf during opening and closing of the gate. The drive system can be either electric or hydraulic allowing for variable speeds and smooth operation.

The SC3000S carries a K4 engineered rating which will stop and destroy a 15,000 lb vehicle traveling at 30mph. The gate can be tailored to match the surrounding décor in a wide variety of architectural enhancements, while still providing ultimate perimeter protection. The gate can be ordered in lengths up to 30' as well as custom heights. Delta is the de-facto choice for custom applications.

Crash Rating	Foundation Depth	Normal Operating Speed	Emergency Operating Speed	Height	Widths	Configurations
K4 Engineered	52"	1.5 feet per second - Adjustable	N/A	108" Standard	9' - 30'	Electric or Hydraulic

Foundational Drawing

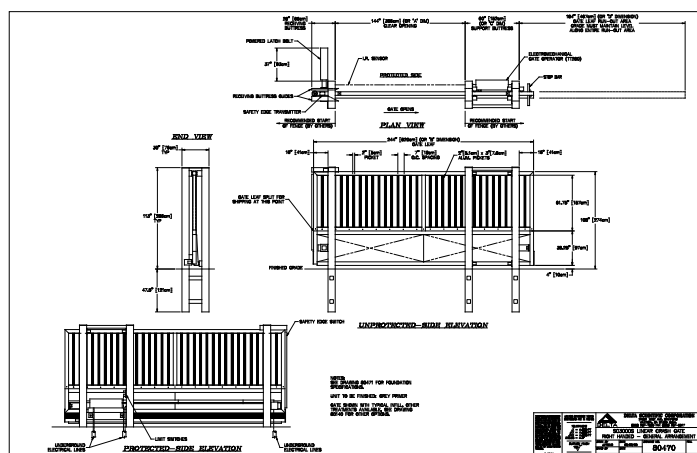

SGC1000

High Security Swing Gate

K4 Crash Rated Manual Swing Gate

Certified By: Engineered Rated

Certification Level: K4

Installation Design: Swing Gate



Delta Scientific's SGC1000 high security swing gate was designed to fill the need for a rugged manually operated crash-rated swing gate. The design of the end support assemblies add to its crash rated performance. A ground track is not needed. The SGC1000 provides a clear opening of 12 to 30 feet (3,657 mm to 9,144 mm).

The gate can be tailored to match the surrounding decor in a wide variety of architectural treatments. The SGC1000 also comes in an automated version. The gate is designed to stop and destroy a 15,000 lb vehicle traveling at 30mph providing your facility with a high level of protection from vehicle borne threats.

Crash Rating	Foundation Depth	Normal Operating Speed	Emergency Operating Speed	Height	Widths	Configurations
K4 Engineered	66"	Manual Swing	N/A	108" Standard	9' - 30'	Manual Swing

General Arrangement

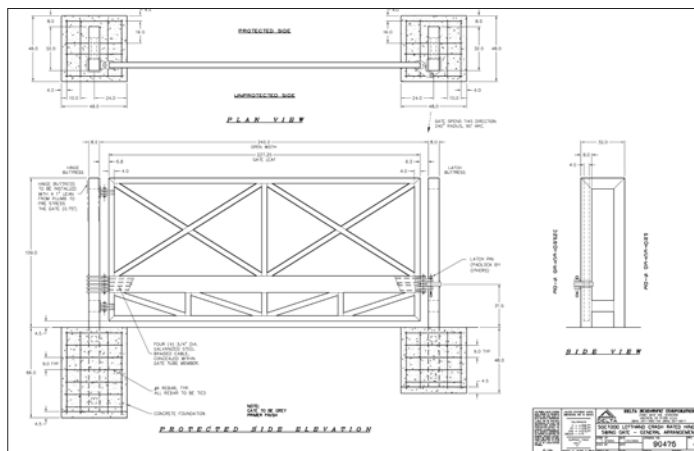

DCS8000

Bi-Fold Speed Gate

Certification Level: M30 - P1

Certified By: ASTM

Model #: DSC8000

Installation Design: Shallow Foundation

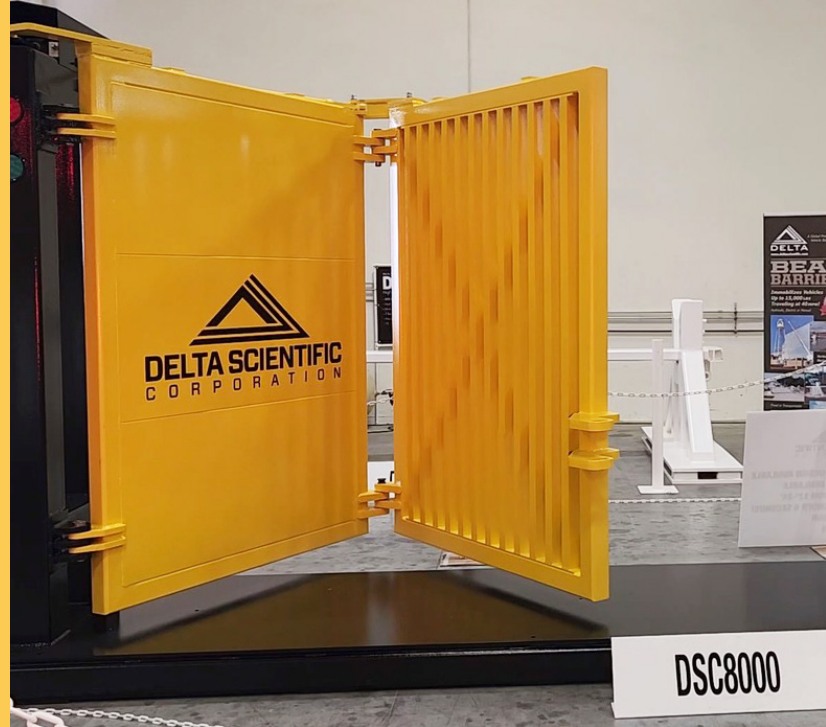

Delta's new DSC8000 bi-fold speed gate is designed to fit into tight spaces and allow moderate to heavy vehicle throughput. With an adjustable opening time of 6 seconds, your facility can easily handle up to 180 cars per hour. Clear openings up to 24' can be covered with a dual hinge design where the gate panels meet in the middle. Full-clad panels or DOS anti-climb picketed infills are available to match the architecture of the surrounding facility.

The DSC8000 is available in an M30/P1 crash tested version or a standard non-crash tested version. The drive mechanism for the DSC8000 can be hydraulic or electric. A pre-hung design allows for the gate to be easily tested at the factory and makes for easy installation with minimal assembly in the field. With a shallow foundation of only 24", the DSC8000 is an easy choice to fit your speed gate needs.

Custom logos and paint colors are available to put the finishing touches on your new speed gate.





Portable Barriers for Vehicle Security Control

First used successfully to protect NATO troops in Kosovo and elsewhere, Delta Scientific's quick deployment, modular portable barrier solutions can be rapidly set up on existing concrete or asphalt roads, level compacted soils and other hard surfaces. No excavation or sub-surface preparation is required.

Delta's portable barriers are used around the world. The Social Security Administration temporarily used them to secure its headquarters while permanent Delta stainless steel bollards were being installed. The U.S. Department of State uses them to protect embassies in locations where permanent barricades are not feasible.

Tow-able barricades answer the need of Delta clients that require a temporary barricade system to address a specific threat or secure a facility during special events. They can also be used as a more permanent solution with the upgrade to the 24v H8050 HPU which allows for more control options and faster speeds.

Built at the request of U.S. Federal Government Force Protection Specialists for initial fast deployment use

in Iraq and elsewhere, the totally self-contained MP5000 is towed into position and controls vehicle access within 15 minutes. Once positioned, the mobile barricade unpacks itself by using hydraulics to raise and lower itself off its wheels. Simply plug in standard 120v or 220v power and you are ready to go. The MP5000 is M40 Certified and comes in lengths of 12', 16' and 20'.

Portable Barrier Products

- MP5000
- MP5000 M50
- DSC1000
- DSC900
- DSC1100
- IP500
- TB100
- TB150
- DSC1500

MP5000

Portable Event Barricade

High Security Portable Barriers

M30 and M40 Crash Ratings

Certified By: U.S. Department of State and ASTM
 Certification Level: K4, M30 / M40
 Installation Design: Portable



The MP5000 is one of Delta's most popular barricades due to its portability and stopping power. Available in widths of 12', 16' and 20', the MP5000 can be towed into place and setup within 25 minutes. These barriers have a self-contained 12v DC power unit (H4050) that allows them to run off standard 120v or 220v power with cycle times of 5-7 seconds. Delta also offers a self-contained 24v DC upgraded power unit (H8050) that allows operating speeds of 2-3 seconds for added security and additional control options. No power available, No problem. The MP5000 can be run off a solar panel option for extreme remote locations where power isn't available. Ease of use, portability, and quick deployment times are what makes the MP5000 Delta's best-selling barricade.

Model	Crash Rating	Foundation Depth	Normal Operating Speed	Emergency Operating Speed	Height	Widths	Configurations
MP5000-12	K4	Surface Mount	5-7 Seconds	2.0 Seconds with H8050 HPU	30.5"	144"	DC Hydraulic or Manual
MP5000-16	M30 / M40	Surface Mount	5-7 Seconds	2.0 Seconds with H8050 HPU	30.5"	192"	DC Hydraulic or Manual
MP5000-20	M40	Surface Mount	5-7 Seconds	2.0 Seconds with H8050 HPU	30.5"	240"	DC Hydraulic or Manual

General Arrangement

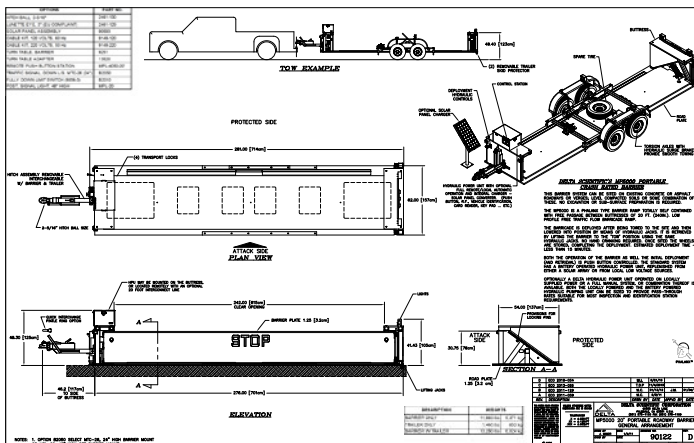

MP5000 M50 Portable Barrier System High Security Portable Barricade M50 Crash Rating

Certified By: ASTM
Certification Level: M50
Installation Design: Portable System



The M50 version of the MP5000 utilizes three TB150 portable bollards attached to each side of the MP5000 buttress that attack the vehicle upon impact. The results are the first portable M50/P3 rated vehicle barrier in the world.

At a time when added protection becomes a priority, the M50 MP5000 allows for highest crash rating available with setup and operation within 45 minutes. It is available in 12', 16', and 20' configurations. The self-contained 12v battery operated HPU simply plugs into the nearest 120v/220v power source.

You can upgrade to our H8050 24v battery powered HPU and make it a more permanent solution with quicker speeds and more control options that still runs off a standard 120v/220v socket.

Crash Rating	Foundation Depth	Normal Operating Speed	Emergency Operating Speed	Height	Widths	Configurations
M50/P3	Surface Mount	5-7 Seconds	2.0 Seconds with H8050 HPU	30"	12', 16' and 20'	DC Hydraulic or Manual

Foundational Drawing

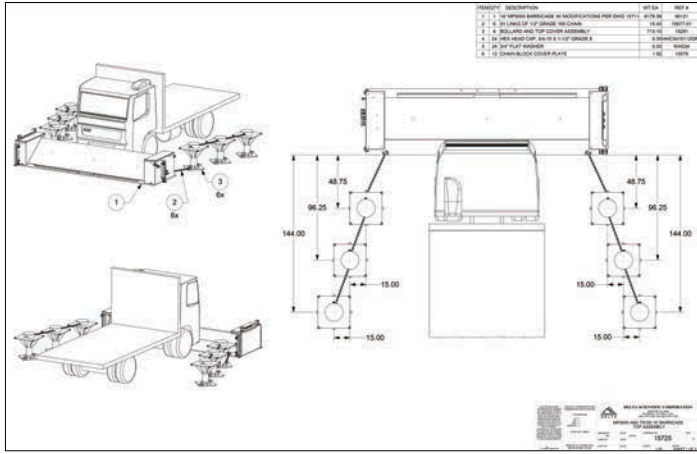

DSC1000

Portable Event Barricade

Medium Security Portable Barriers

PU40 Crash Rating

Certified By: ASTM
 Certification Level: PU40
 Installation Design: Portable



The first in a new category of commercial, crash-tested vehicle barriers, the DSC1000 is a self-contained unit that is stored and towed on its own trailer. Municipalities, event organizers and others that stage temporary events, ranging from farmers' markets to concerts and sporting events, need a commercial barrier that can be towed into place to protect attendees as well as an errant driver. Using Delta's Soft Stop technology, the DSC1000 stops such drivers from inflicting harm upon pedestrians and themselves.

In many cases, the tragedies that the DSC1000 will prevent are accidents. Authorities want the vehicle stopped but they also want to avoid injury to the driver as much as possible. Contrary to the "hard stop" wanted with anti-terrorist crash-tested barricades, testing of the new DSC1000 demonstrated that a collision does not distort the passenger compartment of the vehicle. Instead, Soft Stop technology decelerates and stops the vehicle over a short distance, technically referred to as "occupant ride down acceleration."

Crash Rating	Foundation Depth	Normal Operating Speed	Emergency Operating Speed	Height	Widths	Configurations
PU40/P3	Surface Mount	5-7 Seconds	N/A	29"	120"	DC Hydraulic or Manual

General Arrangement

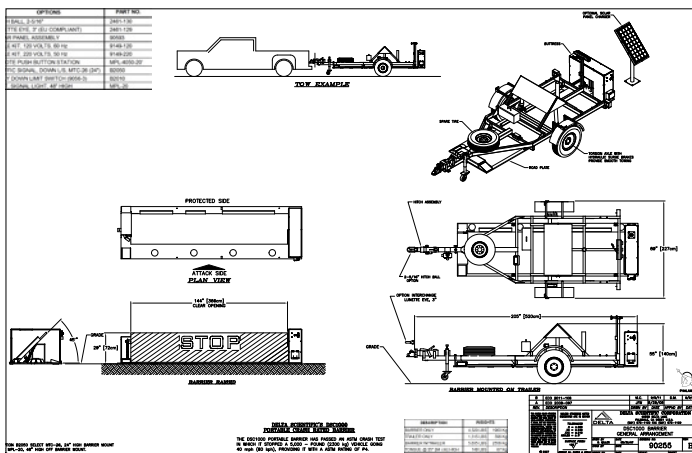

DSC900 and DSC1100 Portable Barricade High Security Portable Barriers K4 and K8 Crash Rating

Certified By: U.S. Department of State, Engineered
Certification Level: K4, K8
Installation Design: Portable



DSC1100

The DSC1100 and DSC900 portable crash rated barriers provides security against vehicle-based terrorism or thefts for high-cycle locations such as the entrances to large office facilities, government agencies and military bases. Able to be deployed in high traffic locations for full manual or automatic operation within two hours, Delta Scientific's quick deployment modular Series DSC1100 Barricade features a phalanx-type rising plate barrier mounted within multiple inertial pods.

DSC1100	Crash Rating	Foundation Depth	Normal Operating Speed	Emergency Operating Speed	Height	Widths	Configurations
	K4/L2, K8/L1	Surface Mount	5-7 Seconds	2.0 Seconds with H8050 HPU	27"	12' - 20'	DC Hydraulic or Manual

DSC900	Crash Rating	Foundation Depth	Normal Operating Speed	Emergency Operating Speed	Height	Widths	Configurations
	K4 Engineered	Surface Mount	5-7 Seconds	2.0 Seconds with H8050 HPU	22"	12' - 20'	DC Hydraulic or Manual

General Arrangements

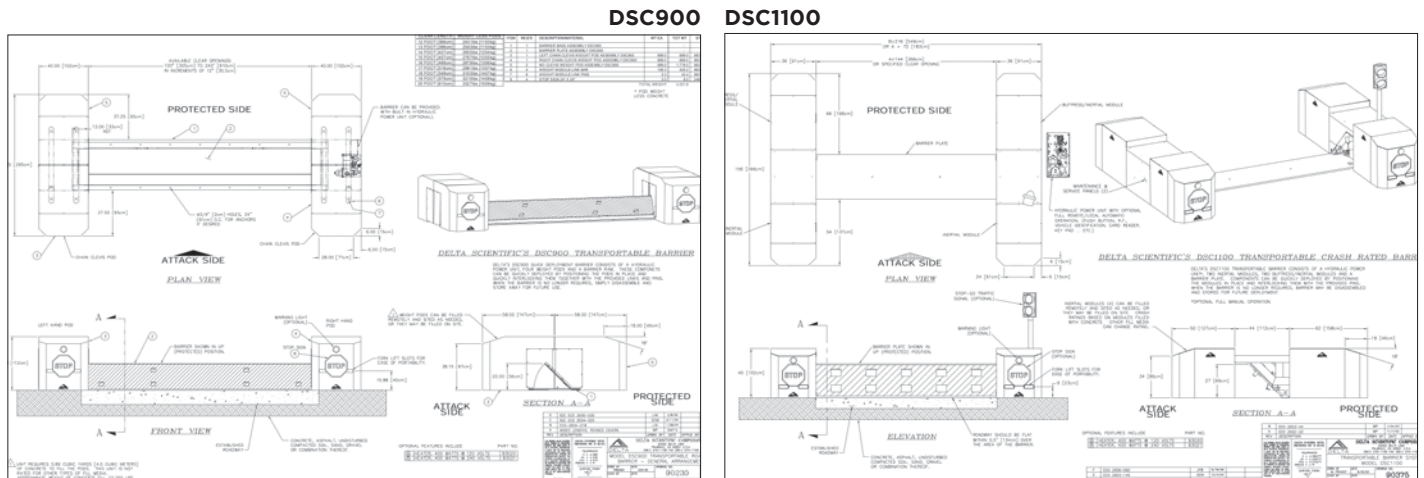

IP500 Portable Beam Barricade High Security Portable Barriers

K4 Crash Rating

Certified By: U.S. Department of State

Certification Level: K4

Installation Design: Portable



High Security Portable Barriers

Able to be deployed or relocated for full manual or automatic operation within two hours, Delta Scientific's quick deployment Series IP500 K-4 Crash Rated Barricade will stop and destroy a 15,000 pound (6,800 kg) truck traveling at 30 mph (48 km/h) in less than 20 feet (6 m).

The IP500 secures an entrance roadway 8 to 20 feet in width from vehicle attack. Hydraulic and manual versions are available. The IP500 is filled with cement once it is in place. This special event barricade is movable and reusable.

Crash Rating	Foundation Depth	Normal Operating Speed	Emergency Operating Speed	Height	Widths	Configurations
K4 Engineered	Surface Mount	5-12 seconds	N/A	22"	12' - 20'	DC Hydraulic or Manual

General Arrangement

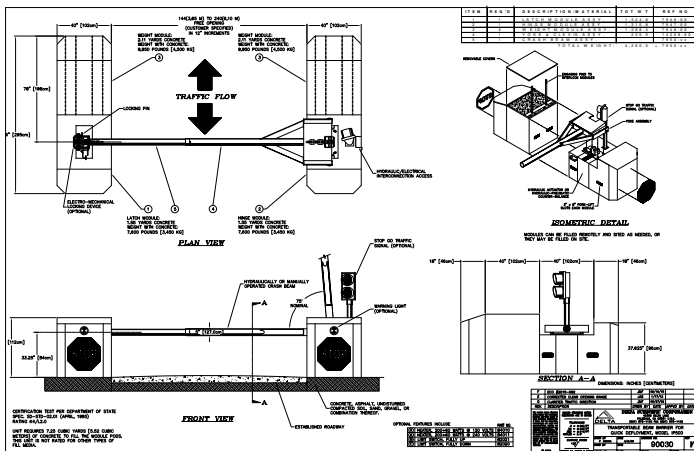

TB100 and TB150

Portable Crash Rated Bollards

High Security Portable Bollards

M30 and M50 Crash Ratings

Certified By: ASTM
Certification Level: M30 / M50
Installation Design: Portable



The new patent-pending TB100 and TB150 crash-rated portable bollards allows law enforcement and security providers to quickly create high security special event barricades that block access to temporary venues where vehicles can be used as weapons against large numbers of pedestrians. Individual portable security bollards provide vehicle barricades in applications such as heavily traveled narrow walkways and roadways or any area that a vehicle can get through. They can also be used as substitutes until permanent bollard systems get installed. The omni-directional design absorbs impact from any angle and its quick deployment enables protection that slows, trips and arrests intruding vehicles without difficulty of a major barricade installation. Pedestrian access points are available to allow foot traffic through the bollard system.

TB100	Crash Rating	Foundation Depth	Normal Operating Speed	Emergency Operating Speed	Height	Widths	Configurations
	M30/P3	Surface Mount	N/A	N/A	35"	Unlimited	Portable

TB150	Crash Rating	Foundation Depth	Normal Operating Speed	Emergency Operating Speed	Height	Widths	Configurations
	M50/P3	Surface Mount	N/A	N/A	35"	Unlimited	Portable

General Arrangement

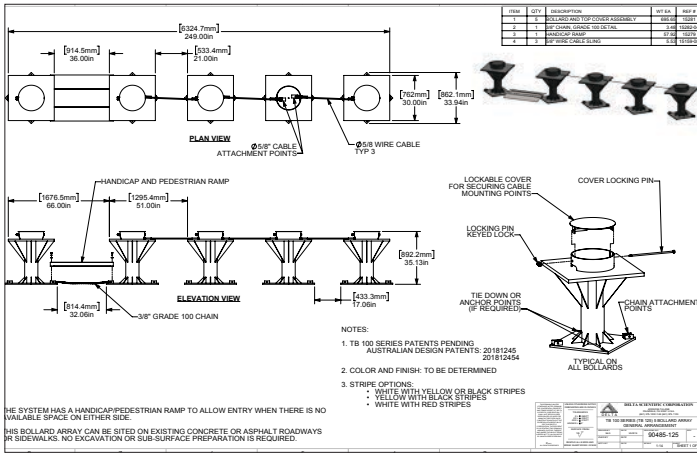



Surface Mounted Wedge Barricades

Delta's surface mounted wedge barricades feature quick installation into difficult locations such as parking structure ramps or areas with sub-surface drainage problems.

These barricades are lowered to allow passage of authorized vehicles and are available in widths up to 240 inches (6096 m). They are crash rated. Surface mounted barricades are very easy to install and provide high security vehicle access control system for banks, city and federal government offices, museums, corporate buildings, factories, oil refineries, railway, airport and other transportation hubs as well as other facilities threatened by truck bomb attack, errant drivers or car-crashing thieves.

With fast installation, shallow or no foundations, low maintenance, certified compliant to industry standards, and all weather operation, Delta Scientific leads the industry with these surface mounted wedge barriers.



Surface Mounted Products

- TT207SFM
- DSC1200
- DSC1450
- DSC1425
- TW2015
- TW4030

TT207SFM

Surface Mount Barricade

High Security Surface Anchored Barrier

K12/L3 Crash Rating

Certified By: U.S. Department of State
 Certification Level: K12
 Installation Design: Surface Mounted



Surface Mounted Wedge Barricades

The TT207SFM will stop and destroy a 15,000 lb truck traveling at 50 mph achieving the K12 rating. This barrier easily anchors to a pre-poured concrete pad so you don't have any excavation or worry about hitting underground utilities. When the TT207SFM barrier is in the up position the hydraulics are protected by the heavy steel ramp plate.

The barrier comes in lengths from 9' to 20' to protect standard size roads as well as larger roadways. Designed for easy installation, the TT207SFM can also be used on driveway ramps as well as parking garages. Delta also offers a cast-in-place version of the TT207SFM with a shallow foundation of only 13".

Crash Rating	Foundation Depth	Normal Operating Speed	Emergency Operating Speed	Height	Widths	Configurations
K12/L3	Surface Anchored	3-5 Seconds	2.0 Seconds	38.5"	9' - 20'	Hydraulic

General Arrangement

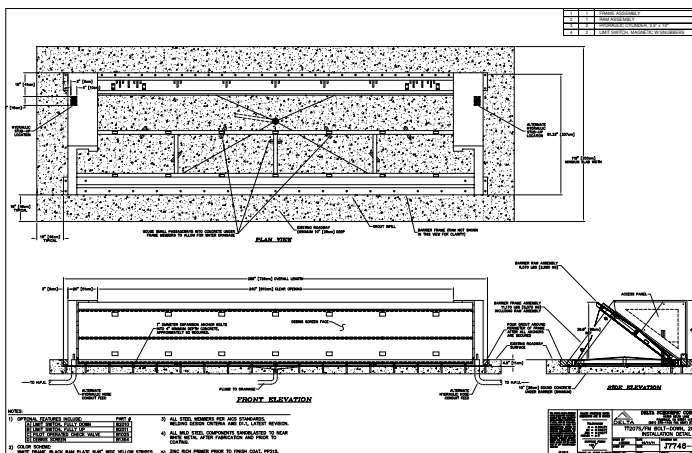

DSC1200

Surface Mount Barricade

High Security Surface Anchored Barrier

K4/L3 Crash Rating

Certified By: U.S. Department of State
Certification Level: K4
Installation Design: Surface Mounted



Surface Mounted Wedge Barricades

The new Delta Scientific DSC1200 surface mounted barricade provides a very easy to install high security vehicle access control system for banks, city and federal government offices, museums, corporate buildings, factories, oil refineries, railway, airport and other transportation hubs as well as other facilities threatened by truck bomb attack, errant drivers or car-crashing thieves. Installers can simply epoxy or bolt the new DSC1200 barricade to an already-existing concrete slab. Since there are no drainage or underground utilities issues, installation is fast.

Ready to operate, the DSC1200 surface mounted high-security barricade features a self-contained motor drive in one butress. Stop-and-go signal lights and access control logic are also built-in. To manage the barricade, operators use touch screen control panels, which simply plug into the barricade's control circuits. The DSC1200 high security barricades are also perfect for high water table locations and areas with corrosive soils.

Crash Rating	Foundation Depth	Normal Operating Speed	Emergency Operating Speed	Height	Widths	Configurations
K4/L3	Surface Anchored	3-5 Seconds	2.0 Seconds	32"	9' - 20'	Hydraulic or Electric

General Arrangement

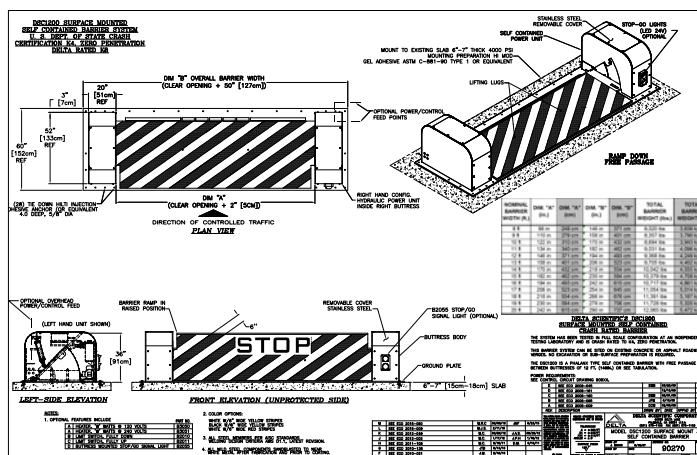

DSC1450

Surface Mount Barricade

Medium Security Surface Anchored Barrier

K4 Crash Rating

Certified By: Engineered Rated
Certification Level: K4
Installation Design: Surface Mounted



Surface Mounted Wedge Barricades

The Delta Scientific DSC1450 surface mounted vehicle barricade consists of four components that provide quick high-security vehicle access protection. Two buttresses, a road plate and hinge plate. The four separate component design makes for easy shipment, handling, and installation.

The barrier components are lag bolted in place to existing concrete surfaces such as parking structures and parking lots to be used as an anti-theft device and or traffic control device.

The barricade features a self-contained programmable electro-mechanical or hydraulic drive system, controls and an integral barrier arm. Typical installation is four hours or less.

Crash Rating	Foundation Depth	Normal Operating Speed	Emergency Operating Speed	Height	Widths	Configurations
K4 Engineered	Surface Anchored	3-5 Seconds	2.0 Seconds	24.5"	9' - 20'	Hydraulic or Electric

General Arrangement

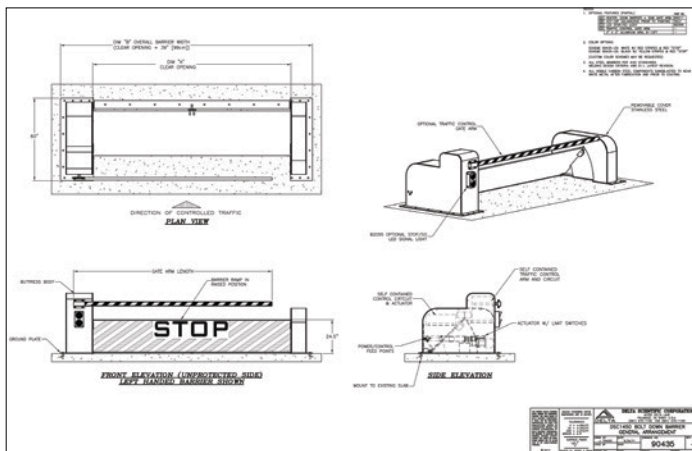

DSC1425

Surface Mount Barricade

Medium Security Surface Anchored Barrier

K4 Crash Rating

Certified By: Engineered Rated
Certification Level: K4
Installation Design: Surface Mounted



The DSC1425 is a surface mounted vehicle barricade that consists of three components: one buttress, a road plate and hinge plate. The four separate component design makes for easy shipment handling and installation. The barrier components are lag bolted in place to existing concrete surfaces such as parking structures and parking lots to be used as an anti-theft device and or traffic control device. The barricade features a self-contained programmable electro- mechanical drive system or hydraulic drive system, controls and an integral barrier arm. Typical installation is four hours or less.

This quick installation surface mounted barrier has a single buttress that houses all the necessary components to run the unit. Simply bring in power to the buttress side of the barrier and run your control wire to your desired location and you are ready to go. This barrier can be left handed and right handed to cover larger openings or orient the barrier as needed for power.

Crash Rating	Foundation Depth	Normal Operating Speed	Emergency Operating Speed	Height	Widths	Configurations
K4 Engineered	Surface Anchored	3-5 Seconds	2.0 Seconds	24.5"	9' - 12'	Hydraulic or Electric

General Arrangement

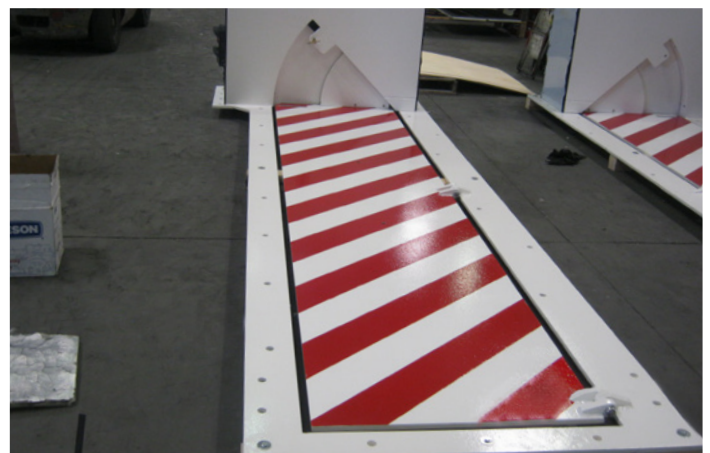
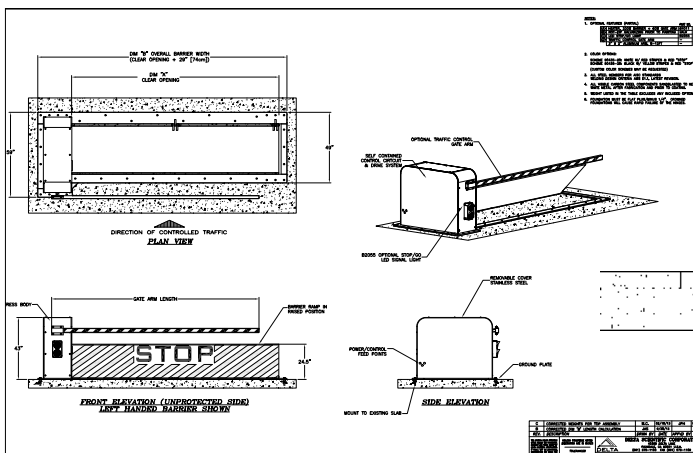

TW2015 & TW4030

Surface Mount Barricades

Medium Security Surface Anchored Barrier

K1 and K4 Crash Rating

Certified By: Engineered Rated
Certification Level: K1 and K4
Installation Design: Surface Mounted



TW2015

Surface Mounted Wedge Barricades

The TW2015 Hydraulic Wedge Barricade System is a one-inch thick ramp that features quick installation. It is designed to install at difficult locations such as parking structure ramps or areas with sub-surface drainage problems and used for intermediate security applications. The TW2015 is a 120-inch (3,048 mm) moving ramp, 22" (558 mm) high that is surface mounted. Crash rated, the barricades are lowered to allow passage of authorized vehicles.

Delta Scientific's TW4030 is a surface mounted, dual buttress wedge barricade system consisting of a heavy steel plate capable of being rotated from the free pass position to its guard position by a hydraulic power unit. Barricade height is 22" (558 mm). Standard clear opening width is 12 feet (3.66m). Maximum width is 20 feet (6.1m).

TW2015	Crash Rating	Foundation Depth	Normal Operating Speed	Emergency Operating Speed	Height	Widths	Configurations
	K1 Engineered	Surface Anchored	3-5 Seconds	2.0 Seconds	22"	9' - 12'	Hydraulic

TW4030	Crash Rating	Foundation Depth	Normal Operating Speed	Emergency Operating Speed	Height	Widths	Configurations
	K4 Engineered	Surface Anchored	3-5 Seconds	2.0 Seconds	22"	9' - 20'	Hydraulic

General Arrangement

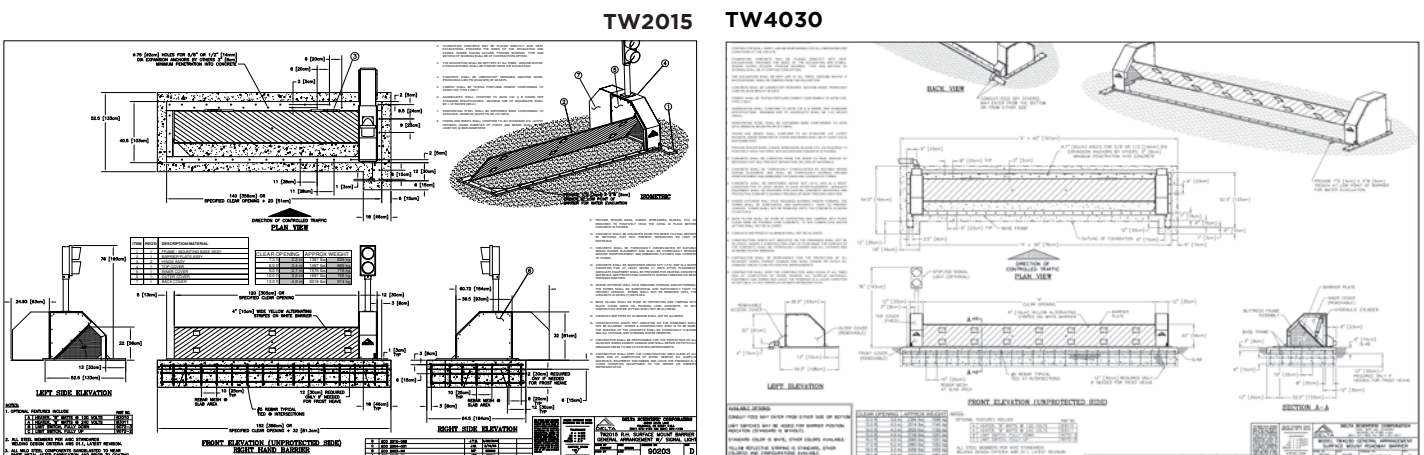



Guard Booths for Security, Ticketing, Parking and Shelter

Delta Scientific produces booths and shelters that provide fast and affordable solutions for a wide range of applications. Whether protecting personnel from bio or chemical hazards or unwanted access at border and military installations, or protecting people from the elements, Delta's booths and shelters are ready fully equipped and ready to be installed in almost any location.

Guard booths (or a similar security guard house or ticket booth) can be used to control security for employees or attendees at stadiums, theme parks, manufacturing facilities, fueling stations, or anywhere a secure entry point is necessary. From small revenue control such as a parking booth or more elaborate guardhouses suitable for multiple security personnel, our guard booths and transit shelter options are designed to work for your company's need.



Guard Booth Products

- High Security Guard Booth
- Standard Guard Booth
- Mail Room Bio Booth
- Customer Booth / Ticket Booth
- Portable Guard Booth

Guard Booth Ratings

Ratings of Bullet Resistant materials as identified by UL 752

Rating	Ammunition	Weight (grains)	Weight (grams)	min fps	max fps	Number of shots
Level 1	9mm Full Metal Copper Jacket with Lead Core	124	8.0	1175	1293	3
Level 2	.357 Magnum Jacketed Lead Soft Point	158	10.2	1250	1375	3
Level 3	.44 Magnum Lead Semi-Wadcutter Gas Checked	240	15.6	1350	1485	3
Level 4	.30 Caliber Rifle Lead Core Soft Point (.30-06 Caliber)	180	11.7	2540	2794	1
Level 5	7.62mm Rifle Lead Core Full Metal Copper Jacket Military Ball (.308 Caliber)	150	9.7	2750	3025	1
Level 6	9mm Full Metal Copper Jacket with Lead Core	124	8.0	1400	1540	5
Level 7	5.56mm Rifle Full Metal Copper Jacket with Lead Core (.223 Caliber)	55	3.56	3080	3383	5
Level 8	7.62mm Rifle Lead Core Full Metal Copper Jacket Military Ball (.308 Caliber)	150	9.7	2750	3025	5
Level 9	.30-06 caliber rifle, steel core, lead point filler, FMJ (APM2)	166	10.8	2715	2987	1
Level 10	.50 caliber rifle, lead core FMCJ Military Ball (M2)	709.5	45.9	2810	3091	1
Shotgun	12-Gauge Rifled Lead Slug	1 oz.	28.3	1585	1744	3
Shotgun	12-Gauge 00 Buckshot (12 pellets)	1.5 oz	42	1200	1320	3

Ratings of Bullet Resistant materials as identified by National Institute of Justice (NIJ) 018.01

Rating	Ammunition	Weight (grains)	Weight (grams)	Min/Max (meters/sec)	Min/Max (feet/sec)	Number of shots
Level I	.22 long rifle high velocity lead	40	2.6	320 +/- 12	1050 +/- 40	5
Level I	.38 special round nose lead	158	10.2	259 +/- 15	850 +/- 50	5
Level II	.357 mag. jacketed soft point	158	10.2	425 +/- 15	1395 +/- 50	5
Level II	9mm full metal jacket	124	8.0	358 +/- 12	1175 +/- 40	5
Level IIA	.357 mag. jacketed soft point	158	10.2	381 +/- 15	1250 +/- 50	5
Level IIA	9mm full metal jacket	124	8.0	332 +/- 12	1090 +/- 40	5
Level III	7.62mm (.308 Winchester) full metal jacket	150	9.7	838 +/- 15	2750 +/- 50	5
Level IIIA	.44 mag. lead semi-wadcutter gas checked	240	15.55	426 +/- 15	1400 +/- 50	5
Level IIIA	9 mm full metal jacket	124	8.0	426 +/- 15	1400 +/- 50	5
Level IV	.30-06 armor piercing	166	10.8	868 +/- 15	2850 +/- 50	1

High Security Guard Booth

Use applications: Border Stations, Federal & State Buildings, Military Bases, Courthouses



Pre-wired to N.E.C (125 AMP, 120/240 Volt, 6/12 station, single phase), the fully assembled High Security Guard Booth is ready for service. Delta's High Security Guard Booths come in a variety of sizes ranging from as small as 4' x 6' all the way up to 14' x 20'. In some custom instances, as shown in the picture above at the San Ysidro Border Crossing, Delta has produced Bullet Resistance booths that span over 40'. With Bullet Resistant levels from Level 1 to 10, Delta's booths will keep your security forces safe from rounds as high as a .50 caliber rifle.

Delta's booths are manufactured to meet tight specification requirements including structural calculations and wet seals from drawings by a registered California Structural Engineer when necessary. Our booths have been tested and certified to UL752. Optional features include air conditioning, heating, padded flooring, bathrooms, pitched roofing, and many other accessories that can be added to meet your needs.



Standard, Custom and Ticket Guard Booths

Prefabricated Booths shipped fully assembled



We manufacture our booths to meet individual site conditions. We're not limited to size constraints and welcome the challenge of building custom booths. They are designed to provide protection from the changing environment and to offer security to your facility. Pre-wired to N.E.C. (125 AMP, 120/240 Volt, 6/12 station, single phase), standard booths are fully assembled and ready for service.

Prefabricated buildings are shipped fully assembled, ready for installation. All structural members meet or exceed ASTM A500. Steel tubing to be 2" x 2" x .083. Sheet metal to be 14 GA. CRS, (galvanized/pre-primed). Sliding door fabricated from structural steel with top suspension aluminum track ball bearing carriers.

Heavy duty steel counter with electrical access port. Steel window frames with 1/4" clear tempered safety glazing. Fluorescent light fixture with (2) 40 watt tubes and a single pole switch. Electrical cabinet with duplex outlets, 125AMP, 120/240 volt, 6/12 station load center and 1500 watt heater.



Mail Room Inspection BioBooth

Self-contained, prefabricated, pre-wired, and uses UL Components



The Mail Room BioBooth is self-contained, prefabricated, pre-wired and uses UL Components. The BioBooth mail screening booth has been designed for inspectors to safely receive and open mail, isolating the rest of the staff and facility from exposure if bio-hazards are suspected. Designed with major input from the U.S. Department of State, the BioBooth concept can be the first line of biological weapons defense for many governmental and corporate organizations worldwide. The Mail Room Inspection BioBooth is typically installed outside of a main building or inside a shipping and receiving warehouse. When attacked by biological hazards, facilities such as post offices will no longer face a lengthy closure.

Upon discovering contaminated mail, the BioBooth can be sealed, quickly unbolted, and contaminated materials can be removed to a containment basin. Delta's Mail Room Inspection BioBooths feature outer and inner workrooms with sealed doors, lighting and hospital style floors. Each room has long countertops and open spaces for staging, sorting and decontamination.

A bench top-mounted HEPA-filtered laboratory hood with UV sterilization is pre-installed and may be flexibly positioned to isolate and protect the inspector opening the packages. The booths have controllable drainage and an internal wash-down hose bib. An optional sub-floor basin catches the contaminated liquid for removal through a valve into a disposal container.

The units fit into sea-going open top shipping containers and are available in a wide range of national and international voltages. Both standard and custom size BioBooths are available.





Parking Lot Gates & Traffic Teeth

Whether the need is to control access, monetize private parking or commercial areas, or provide an extra level of security to public and private spaces, Delta Scientific provides solutions for each. Our wide range of traffic control tire spikes allow for any application where you want to control vehicles from properly entering and exiting your facility.



Sabre Tooth Controllers

Sabre Tooth Traffic Control Tire Spikes enforce "One Way" traffic flow for parking facilities or other single direction vehicle lanes.



Motorized Traffic Controllers

Control spikes are designed to provide protection against unauthorized traffic moving through a protected gate.



Parking Control Gates

Delta's line of parking control gates helps keep vehicle throughput to the necessary level your facility requires.



Parking Lot Warning Signs

Delta Scientific manufactures aluminum body parking lot warning signs with unbreakable sign faces in a variety of colors.



Sabre Tooth Traffic Controllers Cut “Wrong-Way” Exits

Sabre Tooth Traffic Controllers enforce “One Way” traffic flow for parking facilities or other single direction vehicle lanes. The tension spring actuated sabre teeth positively control traffic in one direction while permitting free flow in the other direction. The Sabre Tooth will puncture all pneumatic tires including steel belted radial and large truck tires. Motorized Traffic Controllers provide protection against unauthorized traffic moving through a protected gate.

Sabre Tooth Traffic Controllers & Motorized Traffic Control Spike Model Information

Specifications & Options	TC8	TC12	TC14	TC20	TC20	TC28
Length	36"	72"	36" or 72"	72"	36"	36" or 72"
Width	21.5"	8"	10"	10"	21.5"	10"
Weight (Approximate)	155 lbs	125 lbs	130 lbs	146 lbs	130 lbs	150 lbs
Latch Down Mechanism Available	•	•	•	•	•	•
Surface Mounted	•			•	•	
Flush Mount		•	•	•		•
Galvanized Available	•	•	•	•	•	•
Heavy Duty	•		•			•
Available in 3'	•		•		•	•
Available in 6'		•	•	•		•



TC8 Surface Mounted Sabre Tooth Traffic Controller

The TC8 mounts to an existing drive or ramp (concrete or asphalt) with bolts or epoxy to eliminate excavation and drainage problems. By installing units end-to-end, any width driveway can be controlled.

- Surface Mount for Rapid Installation & Speed Bump Effect
- Mount to Existing Drive Way (Asphalt or Cement) with Bolts or Epoxy
- No Excavation or Cutting Required
- 9 Electroplated Sabre Teeth in 3 Tooth Replaceable Modules
- Long Life Stainless Steel Torsion Springs Body: Alert Red, Teeth: Zinc Plated
- All Welded Steel Frame
- Available in Latch Down Version

TC12 Shallow Frame Sabre Tooth Traffic Controller Flush Mount

- 6 Tooth Modules (12 inches long)
- Long Life Torsion Springs
- All Welded Steel Frame with Reinforcing Bar Runner on each side of body for pull strength
- Top Plate: Alert Red, Teeth: Zinc Plated
- Latch Down Mechanism Available

TC14 Flush Mounted Sabre Tooth Traffic Controller

- Standard Sabre Tooth Controller "The Industry Standard"
- Flush Mount Installation
- 20 Electroplated Teeth made from 3/8 inch steel plate
- Long Life Torsion Springs
- All Welded Steel Frame
- Top Plate: Alert Red, Teeth: Zinc Plated
- Available in Latch Down Version

TC20 Non-Penetrating Flush Mount Sabre Tooth Traffic Controller

- Long Life Torsion
- Springs All Welded Steel Frame
- Top Plate: Alert Red, Barrier Plates: Zinc Plated

TC22 Non-Penetrating Surface Mounted Sabre Tooth Traffic Controller

Similar to the TC8, the TC22 is designed to mount to an existing drive or ramp (concrete or asphalt) with bolts or epoxy to eliminate excavation and drainage problems. The TC22 has non penetrating barrier plates allowing for pedestrian traffic.

- 3 Removable & Reversible 3 Tooth Modules (12" long)
- Long Life Torsion Springs
- Top Plate: Alert Red, Barrier Plates: Zinc Plated
- All Welded Steel Frame
- Latch Down Mechanism Available
- Galvanized Available





TC28 Flush Mounted Sabre Tooth Traffic Controller for Heavy Industrial Traffic

The TC28 is designed to handle extra heavy industrial traffic. Locations where axle loading exceeds known highway specifications are easily handled by the TC28. The unique design of the Tandem Tooth incorporates extra strength axles, top plates, frame supports and anchor tabs.

- Allowable Load 40,000 Pounds Long Life Torsion Springs
- All Welded Steel Frame
- Flush Installation (recessed bolts)
- Frame Epoxy Undercoated
- Top Plate: Alert Red Teeth: Zinc Plated
- Latch Down Mechanism Available
- Galvanized Available

MTC6000 Motorized Traffic Controller

The MTC6000 Motorized Traffic Controller features a modular design, electro-mechanical operation and pedestrian friendly control teeth. The MTC6000 system is designed to control authorized traffic flow on a day-in-day-out basis yet will severely damage or deflate the tires of an unauthorized vehicle, even the new generation of steel belted tires. The MTC6000 system was created for use at car rental agencies, public buildings, airports or high vandalism locations where car theft or fee evasion is of concern.

The Control Teeth are made from high tensile steel with points encased in specially molded caps that break away under the impact and load of a motor vehicle, yet provide protection to a hapless pedestrian that might fall or bump against the unit. The "Pedestrian Friendly" Sabre Tooth Control Teeth are rotated into position by a highly reliable electro-mechanical system in less than 1.5 seconds. The MTC6000 comes in 3 feet (914 mm) modules and can be configured to control traffic ways up to 32 feet (9.14 M) in width.

MTC31 Flush or Surface Mount Traffic Controller

The MTC31 Motorized Traffic Controller features a modular design and electro-mechanical operation. The MTC31 provides top protection against unauthorized vehicle traffic into or out of protected areas. MTC31 systems are in operation in over 5,000 locations worldwide and are providing around the clock protection for car storage lots, rental agencies, airports, government buildings or any location where theft or fee-avoidance is an issue.

The MTC31 comes in 3.0 foot (914 mm) modules that are bolted or epoxy-affixed to the surface of new or suitable existing concrete or asphalt traffic ways to provide the additional advantage of a speed bump. Systems can be ordered to control traffic ways up to 32 feet (9.14 M) in width.





Parking Control Gates

Vehicle gates and beams for parking control needs.

Controlling access into and out of your facility is critical to providing an orderly and structured traffic flow. Delta's parking control gate product line ensures your needs are met in this capacity. Whether it's the automated AG812, SG1420, BB10M or the manual MG137, MG139 and MG215, Delta has you covered. Every application is unique and Delta's ability to cover all of these scenarios is what sets it apart in the barrier industry. Contact a Delta representative today to get pricing and product application advice for your facility.

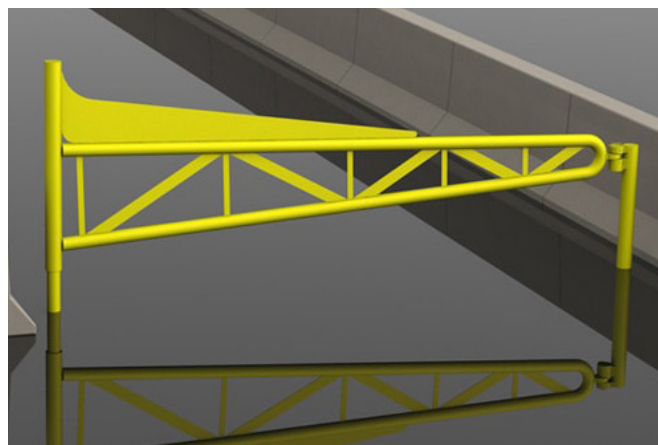

Parking Control Gate Products

- AG812
- SG1420
- MG137
- MG139

AG812 All Purpose Vehicle Access Control Beam

All-purpose semaphore type parking control gate



The AG812 Vehicle Access Gate is an all-purpose semaphore type parking control gate for use with wood or aluminum gate arms. It is designed and configured to meet a broad range of vehicle control and parking needs.

The drive train, the control logic module and the cabinet are built to withstand heavy industrial traffic and parking control requirements. Additionally, they include an interface with revenue systems, vehicle identification systems, card readers, remote control stations and buried detectors. The AG812 is UL listed.

Normal Operating Speed	Arm Height	Arm Lengths	Arm Types	Configurations	Options
1.9 – 2.5 Seconds	35"	8' – 12'	Wood, Aluminum, Straight, Folding	Left or Right Handed	Heaters, Safety DART System, Custom Striping

Drawings

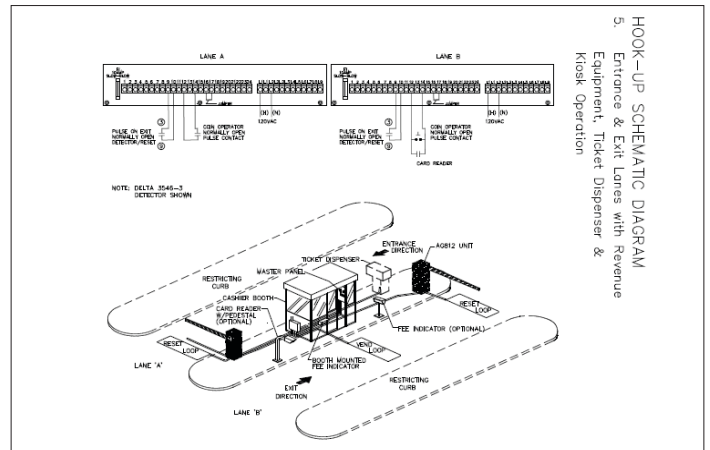
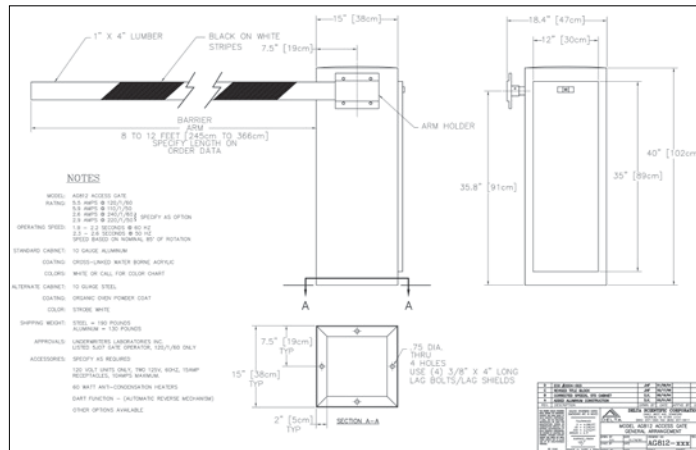

SG1420 Long Arm Parking Control Beams

All-purpose semaphore type parking control gate



The SG1420 high security parking control beam gate is a 13 to 20 foot (3.9m to 6m) double reduction drive gate. The drive train, the control logic module and the cabinet are built to withstand heavy industrial traffic and parking control requirements.

Additionally, they include an interface with revenue systems, vehicle identification systems, card readers, remote control stations and buried detectors. Thus, this gate has all of the features of the AG812 but handles longer arms. It is UL listed.

Normal Operating Speed	Arm Height	Arm Lengths	Arm Types	Configurations	Options
3.8 — 4.4 Seconds	35"	13' – 20'	Wood, Aluminum, Straight, Folding	Left or Right Handed	Heaters, Safety DART System, Custom Striping

Drawings

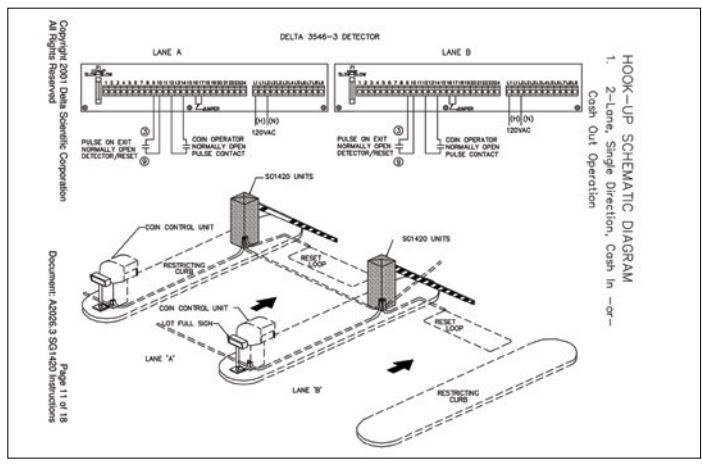
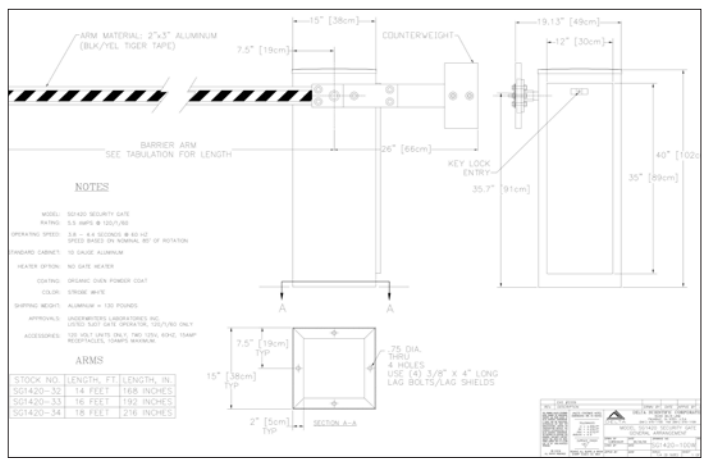

Barricade Control Systems



Junction Box and Control Circuitry

This photograph shows a typical barricade control circuit with an integral motor starter, PCB control board and step down transformer! Delta Scientific builds control circuits to project requirements from the simple to highly complex integrated systems, controlling multiple barricade systems. International voltages are available.



Hydraulic Power Unit - Delta HPU

Top of the line, heavy duty, patented Delta Power Unit barricade control systems. We rack and stack valves, flow controls and accumulators to meet our client's applications for speed of operation, number of barricades to be controlled and the number of power off cycles required.



Electro-Mechanical Control System

Delta Scientific provides a series of Electro-Mechanical barrier systems that take advantage of Programmable Logic Controllers as well as Motion Control Drives to create systems that don't require the use of hydraulic oil. The controllers and drives in the system allow for monitoring and diagnostics of the barrier system as well as motion control.



Hydraulic Pump Enclosure & Housing

Delta's HPU enclosures are designed to withstand the harshest environments and can be painted to match any color. The enclosures allow easy access to all the components from the front of the unit with optional side access doors available. Each enclosure can be also be upgraded to a heavy duty version that includes bullet resistance features and a stainless steel finish.



H8050 24v DC Powered HPU

The H8050 24v DC powered HPU allows you to run the barrier off standard 120v or 220v power. An integrated control circuit and up-graded accumulator allows for multiple barrier control configurations and higher duty usage. Cycle rates of 2 seconds are possible with this hybrid system. Simply plug it into any standard 120/220v socket. Also capable of running off solar panels.



H4050 12v DC Powered Hydraulic HPU

Universal voltage DC powered versions of these pumps are available for remote locations or less frequently operated barricades. These barricade control systems feature long battery life, low amperage trickle charging and solar panel charging.

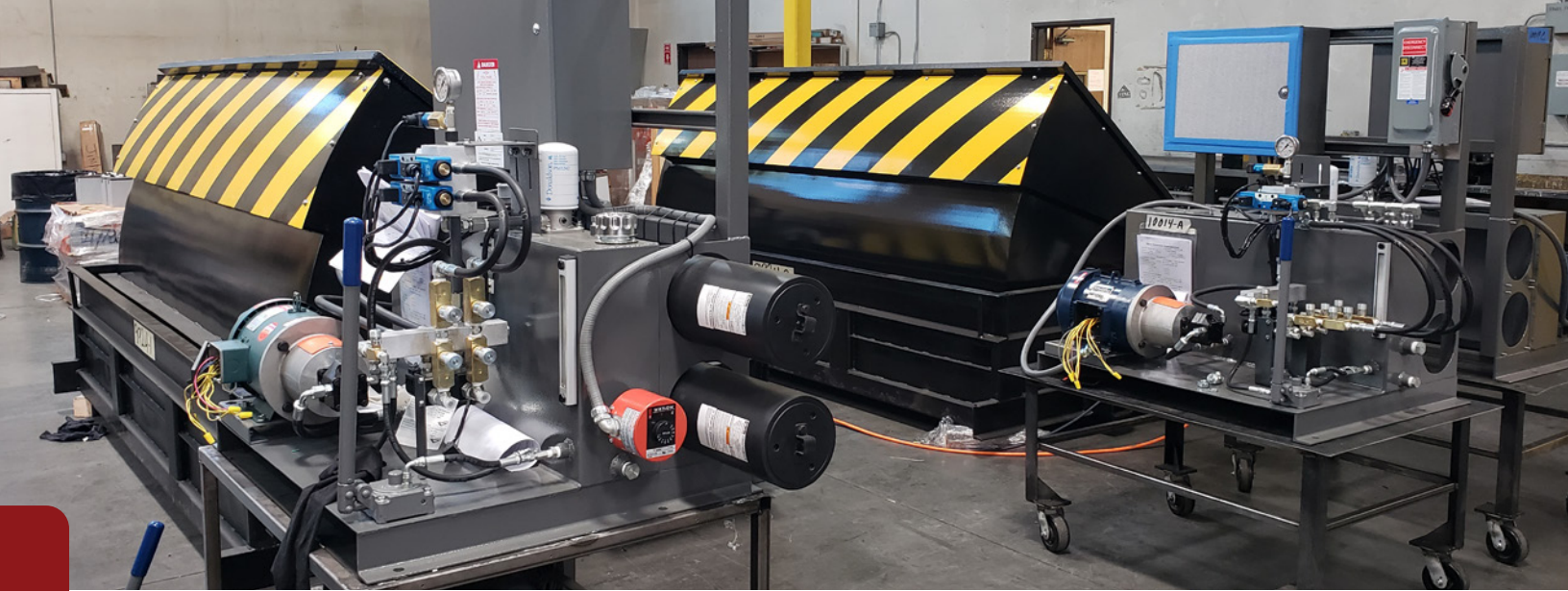

Early Warning Systems

Using Doppler Radar and digital loop detector tech, the Delta DSC400 Early Warning System alerts guards to active security measures and raises Delta vehicle barricades. Once alerted the guards can take action by raising the Delta barricade systems. Continuous Doppler Radar picks up instantaneous changes in velocity and addresses the threat scenario in which an inbound vehicle approaches at normal speeds and then accelerates to commence the attack. It will also warn if a hidden vehicle suddenly passes a larger vehicle and attempts an attack. Once alerted, the guards can take action, including raising the Delta barricade systems.

The Delta DSC400 Early Warning System consists of radar antennas that look like and install similarly to video surveillance cameras. They can be positioned on top of guard booths or on poles looking into the facility or out.



Touchscreen Control and Data Logging System

Convenient and customizable touchscreen panel capable of controlling up to 8 unique barriers or systems on screen sizes from 10 to 20 inches. The B5010 Control Panel is a Customizable Touchscreen Barrier Control Panel with a built in data logging system. The software was designed from the ground up specifically to control our High Security Barrier Systems. Built in Ethernet Communication also allows easy connection and integration into any networked barrier system.

There are dozens of options built into the software to ensure that the control panel accurately matches your specific system setup. Large custom graphics ensure that any user can easily operate the barriers and the built in ability to create and remove users ensures that only those with certified access are able to control the system. Recorded Cycle Counts and Maintenance Alarms make it easy to ensure your barrier properly maintained and functional when you need it to be.

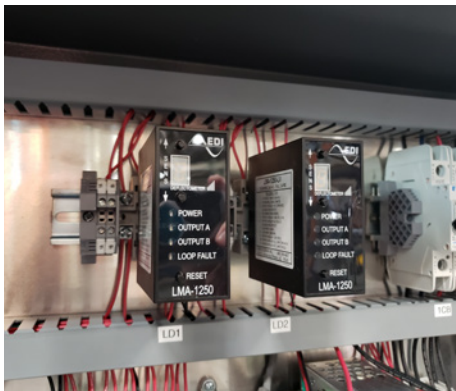

Vehicle Loop Detectors

Delta Scientific's LMA Series Digital Loop Detectors are recommended with all Delta and most other vehicle access barricade control systems because they are programmed to prevent a closing signal when power resumes. LMA Series Loop Detectors are directly interchangeable with most other brands as a plug-in replacement.

These loop detectors provide customers with a safety detector that can prevent accidents which occur when power outages cause vehicle access barricade control systems to reset their logic. The LMA Series incorporates an advanced micro-controller that combines a powerful digital computer and the latest and most advanced inductive vehicle loop technology to give high-test reliability and accuracy when measuring, counting or detecting vehicles.

UVLS100 Undercarriage Vehicle Inspection Lights



The UVLS100 Under Vehicle Inspection Light System is provided as a permanently installed, resin-encased, LED lighting system for use as in-ground up lighting within vehicle traffic lanes to assist with undercarriage inspections.

Components provided conform with the technical specifications by the U.S. Department of State. 120 degree output LED lighting delivers 654 LUX of illumination with a color temperature of 6500 Deg K. A High / Low selectable switch allows for different illumination levels.

Features

Illumination

- 120 Degree Output LED lighting, tested at 12 inches to deliver a minimum of 654 Lux
- UVLS100 "HIGH" output: 3000 LUX
- UVLS100 "LOW" output: 1500 LUX
- Color temperature of 6500 Deg. K.
- Switch selectable High/Low levels of illumination

LED Encasement

- 2 rows of LED lighting encased in water clear Resin
- UV light and oxidation resistant
- Hydrophobic and weather resistant

Power Supply

- 120-240 VAC, 50-60 Hz, power required
- NEMA type 4 enclosure, IP66
- Selectable off delay timer, preset to 30 minutes

Load Profile

- Low output at 80W per single 20 FT LED block
- High output at 160W per single 20 FT LED block

Drawing

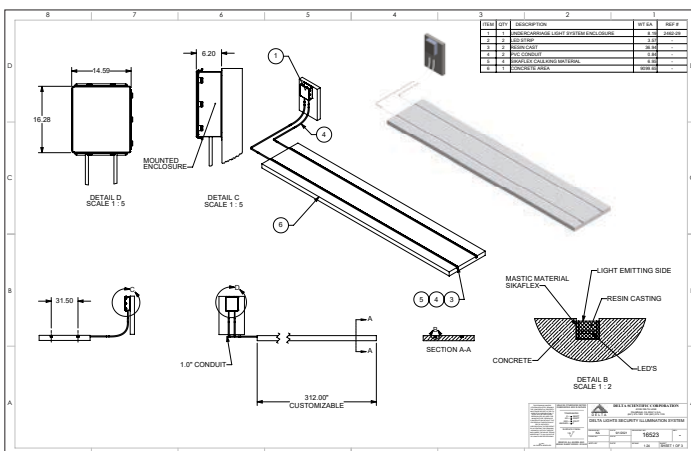



Product Support and Service

Your source for factory-direct maintenance services and technical support.

Not only is Delta Scientific the worldwide leader in the implementation of traffic access control and anti-terrorist vehicle control, it is also the leader in post-installation support. The Delta Scientific Product Support Division is composed of dedicated, highly experienced technicians who have installed, maintained, and serviced hundreds of barrier systems throughout the country and around the world at U.S. Military Bases, Nuclear Facilities, U.S. Embassies, Private Buildings, and other government facilities. Delta Scientific offers a full range of maintenance services as well as onsite training and demonstration. Our technicians and partners have the world covered and can assist with any of your needs.

MAINTENANCE SERVICES

Once we've provided you with turnkey installation services, we don't want our job to be over. In fact, many customers ask us to maintain their systems, keeping them up-to-date and functional, always ready to do their jobs at a moment's notice. Count on the people that created, manufactured and installed your system to help you keep it working properly. We offer monthly, quarterly or semi-annual

maintenance services to cover your needs. We can also come out and diagnose your problems and let you know what will be needed to get the system back up and running.

TECHNICAL SUPPORT

If you have any questions regarding your Delta-provided equipment, don't hesitate to call our technical support team. Who better to answer your questions than the people who designed and manufactured your equipment? Any time of the day or week, contact the Delta technical support team. They have one purpose—to help you get the most out of your Delta barricade and access equipment.

For more information on how you can have a Delta Certified Technician maintain or diagnose your equipment please contact us at the following numbers or fill out the form on this page and a representative will be in touch shortly.

Corporate HQ: Palmdale, CA • (661) 575-1100

Contact Delta Scientific



We look forward to communicating with you!

Please feel free to email us, call by phone or fax, or visit our website.

Corporate Headquarters & Manufacturing Center

40355 Delta Lane, Palmdale CA 93551

Phone: (661) 575-1100

Fax: (661) 575-1109

Email: info@deltascientific.com

Website: deltascientific.com

US Patent #:

4,097,170	4,844,653
4,158,514	5,560,733
4,318,079	10941531B2
4,354,771	US 10,407,852 B2
4,490,068	US 6,382,869 B1
4,576,508	US 2020165787A1
4,715,742	US D903906A1

U.K. Patent #:

GB 2,217,893B
2,136,883B

Australian Design Patent #:

201812454
201812455

