

ITEM	REQ'D	DESCRIPTION	STOCK #
01	1	HINGE POST ASSEMBLY	5866-00
02	1	HINGE END TOP PLATE ASSEMBLY	5671-00
03	1	HYDRAULIC CYLINDER, "x" x 18"	2468-xx
04	2	SHAFT COLLAR, 1.5" DIA	1900-11
05	2	PILLOW BLOCK	1900-10
OPTIONAL	0 or 1	LIMIT SWITCH, FULLY UP	2465-29
OPTIONAL	0 or 1	LIMIT SWITCH, FULLY DOWN	2465-29
OPTIONAL	0 or 1	HEATER, 200 W @ 120 V OR 240 V	2465-4x
OPTIONAL	0 or 1	THERMOSTAT, FACTORY SET 24°C	2465-14
OPTIONAL	1	LATCH POST ASSEMBLY	7256-00
OPTIONAL	1	MANUAL LATCH PIN	5673-10
OPTIONAL	1	CABLE EYE CUSHION	5569-00
OPTIONAL	0 or 1	MAGLOCK, 0.125 AMP @ 24 VDC	2461-50
OPTIONAL	0 or 1	MAGLOCK HEATER, 60 W @ 120 V OR 240 V	2465-5x
OPTIONAL	0 or 1	THERMOSTAT, FACTORY SET 24°C	2465-14
OPTIONAL	1	YOKE ASSEMBLY W/TUBE CLAMPS	5765-00
OPTIONAL	1	CRASH CABLE ASSEMBLY, "C" DIM LG.	7083-"C"
OPTIONAL	1	CRASH TUBE, 4.5" X .083 WALL, "D" DIM LG.	5648-"D"
OPTIONAL	1	TAPE, RED REFLECTIVE, 3" X 20"	2465-109

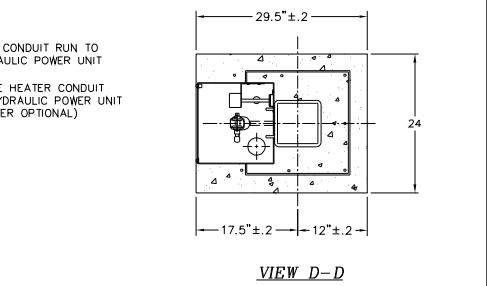
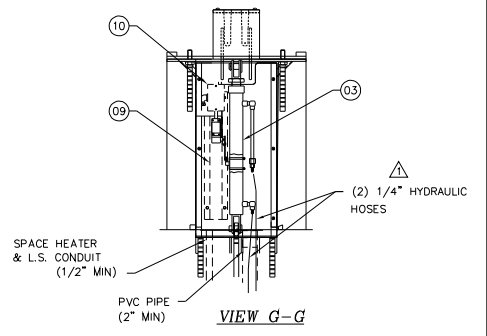
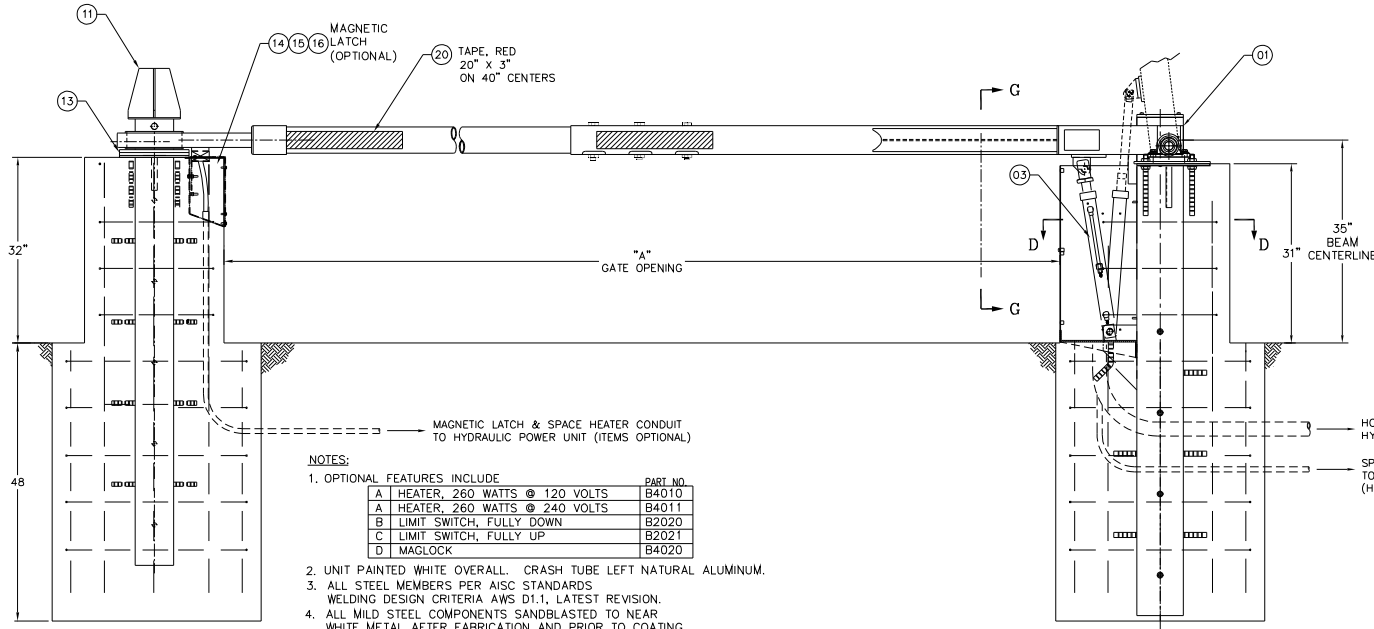

- NOTES:**
- OPTIONAL FEATURES INCLUDE
 

	PART NO.
A HEATER, 260 WATTS @ 120 VOLTS	B4010
A HEATER, 260 WATTS @ 240 VOLTS	B4011
B LIMIT SWITCH, FULLY DOWN	B2020
C LIMIT SWITCH, FULLY UP	B2021
D MAGLOCK	B4020
  - UNIT PAINTED WHITE OVERALL. CRASH TUBE LEFT NATURAL ALUMINUM.
  - ALL STEEL MEMBERS PER AISC STANDARDS WELDING DESIGN CRITERIA AISC D1.1, LATEST REVISION.
  - ALL MILD STEEL COMPONENTS SANDBLASTED TO NEAR WHITE METAL AFTER FABRICATION AND PRIOR TO COATING.
  - DIMENSIONS

TAB	ITEM	DESCRIPTION	FORMULA
'A'		CLEAR OPENING	'A'
'B'		POST CENTERS	'A' + 29.25"
'C'		CABLE LENGTH	'A' + 30"
'D'		CRASH TUBE LENGTH	'A' - 54"
'E'		QUANTITY OF TAPE	INT('A'/20')

REV.	DESCRIPTION	DATE	APP'D BY
B	CORRECTED DIMENSIONS AND DETAILS	JMF 08/03/01	
A	REVISED TO NEW CONFIGURATION	F.R.G. 10/25/99	

UNLESS OTHERWISE NOTED DIMENSIONS ARE IN INCHES	DELTA SCIENTIFIC CORPORATION
TOLERANCES X = ±.0005/IT XX = ±.002/IT XXX = ±.010/IT ANGLES = ±.5°	24801 WEST AVE., STANFORD VALLEJO, CA 94768 U.S.A. (800) 257-1800 FAX (800) 257-0617
DELTA TT212E SERIES CABLE CRASH BEAM BARRIER - GENERAL ARRANGEMENT	
DRAWN BY ANDREW C. DATE 01/31/95	DRAWING NO. 90191
CHECK BY DATE	REV. B
SCALE: 1:1 (D SIZE)	SHEET 1 OF 1