

OPTIONS	PART NO.
HITCH BALL, 2-5/16"	2461-130
LUNETTE EYE, 3" (EU COMPLIANT)	2461-129
SOLAR PANEL ASSEMBLY	90593
CABLE KIT, 120 VOLTS, 60 Hz	9149-120
CABLE KIT, 220 VOLTS, 50 Hz	9149-220
TURN TABLE, BARRIER	9251
REMOTE PUSH BUTTON STATION	MPL-4050-20'
TRAFFIC SIGNAL, DOWN L/S, MTC-26 (24")	B2050
FULLY DOWN LIMIT SWITCH (9056-3)	B2010
POST, SIGNAL LIGHT, 48" HIGH	MPL-20

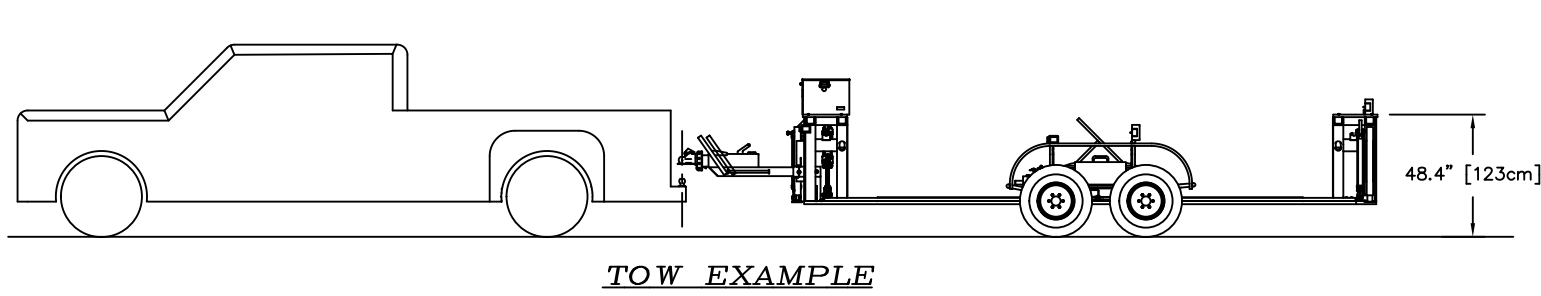

TOW EXAMPLE

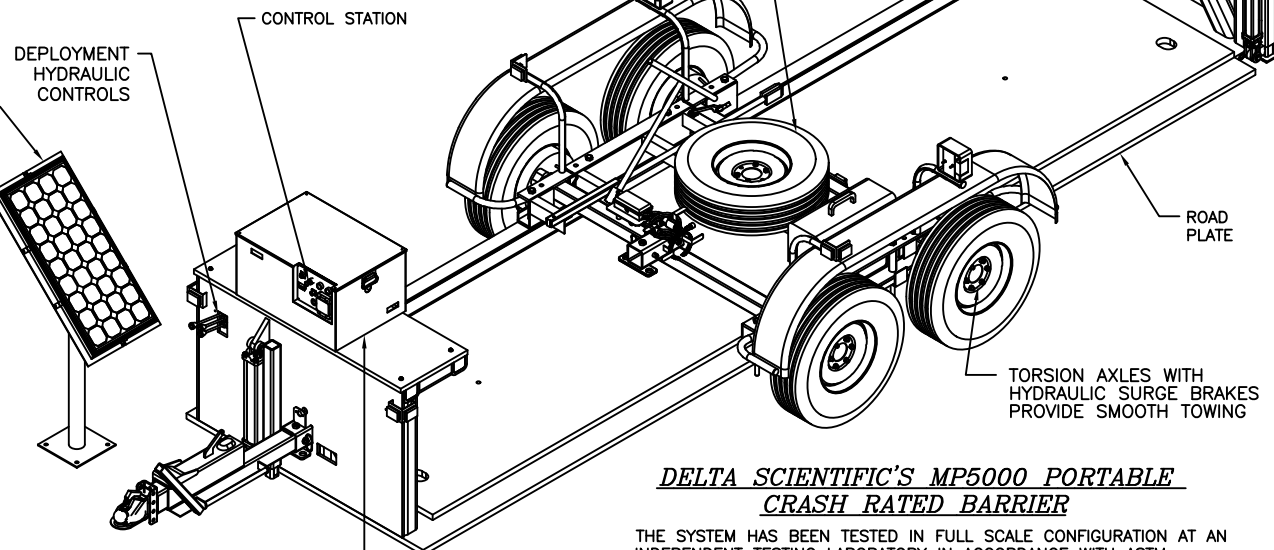
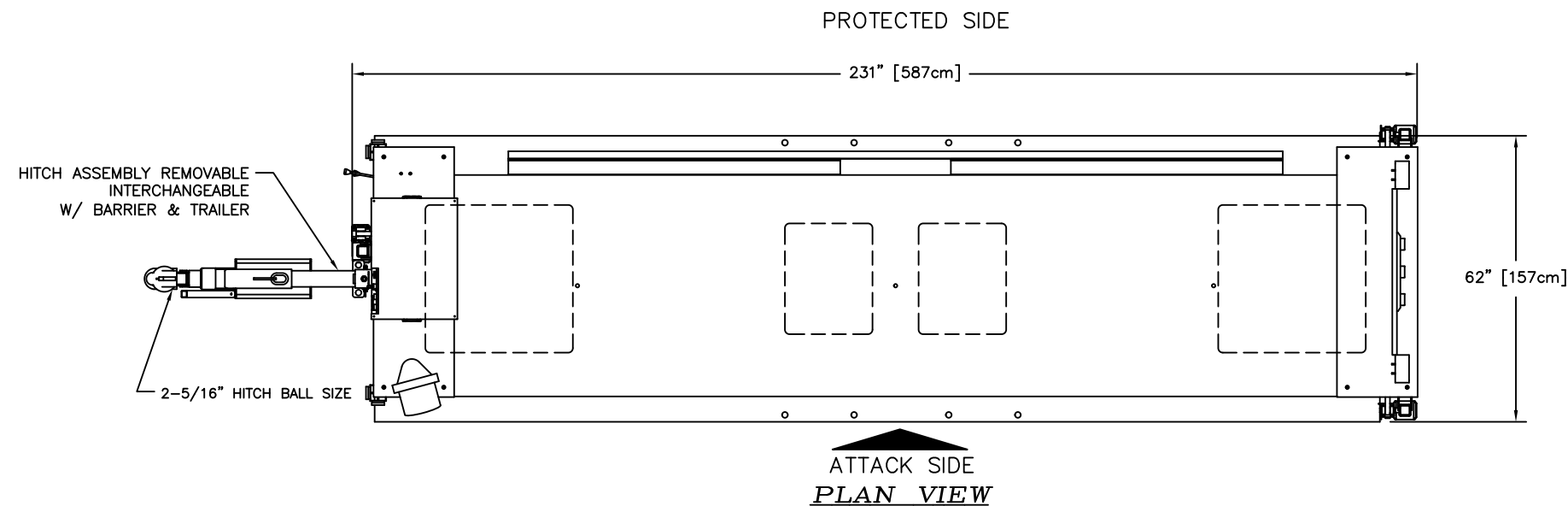

DELTA SCIENTIFIC'S MP5000 PORTABLE CRASH RATED BARRIER

THE SYSTEM HAS BEEN TESTED IN FULL SCALE CONFIGURATION AT AN INDEPENDENT TESTING LABORATORY IN ACCORDANCE WITH ASTM 2656-07 M30 & ASTM 2656-07 M40 (K4,K8). (FULL SCALE CRASH TEST FOR CERTIFICATION SUCCESSFULLY CONDUCTED BY KARCO ENGINEERING, ADELANTO, CA ON MAY 15, 2009). IT IS CONFIGURED FOR EXPEDITED DEPLOYMENT AND, AS NEEDED, RETRIEVAL AND RELOCATION.

THIS BARRIER SYSTEM CAN BE SITED ON EXISTING CONCRETE OR ASPHALT ROADWAYS OR VERGES; LEVEL COMPACTED SOILS OR SOME COMBINATION OF THESE. NO EXCAVATION OR SUB-SURFACE PREPARATION IS REQUIRED.

THE MP5000 IS A PHALANX TYPE BARRIER RAMP TOTALLY SELF CONTAINED WITH FREE PASSAGE BETWEEN BUTTRESSES OF 16 FT. (192IN.). LOW PROFILE FREE TRAFFIC FLOW BARRICADE RAMP.

THE BARRICADE IS DEPLOYED AFTER BEING TOWED TO THE SITE AND THEN LOWERED INTO POSITION BY MEANS OF HYDRAULIC JACKS. IT IS RETRIEVED BY LIFTING THE BARRIER TO THE "TOW" POSITION USING THE SAME HYDRAULIC JACKS. NO HAND CRANKING REQUIRED. ONCE SITED THE WHEELS ARE STORED, COMPLETING THE DEPLOYMENT. ESTIMATED DEPLOYMENT TIME - LESS THAN 15 MINUTES.

BOTH THE OPERATION OF THE BARRIER AS WELL THE INITIAL DEPLOYMENT (AND RETRIEVAL) IS PUSH BUTTON CONTROLLED. THE STANDARD SYSTEM HAS A BATTERY OPERATED HYDRAULIC POWER UNIT, REPLENISHED FROM EITHER A SOLAR ARRAY OR FROM LOCAL LOW VOLTAGE SOURCES.

OPTIONALLY A DELTA HYDRAULIC POWER UNIT OPERATED ON LOCALLY SUPPLIED POWER OR A FULL MANUAL SYSTEM, OR COMBINATION THEREOF IS AVAILABLE. BOTH THE LOCALLY POWERED AND THE BATTERY POWERED HYDRAULIC PUMPING UNIT CAN BE SIZED TO PROVIDE PASS-THROUGH RATES SUITABLE FOR MOST INSPECTION AND IDENTIFICATION STATION REQUIREMENTS.

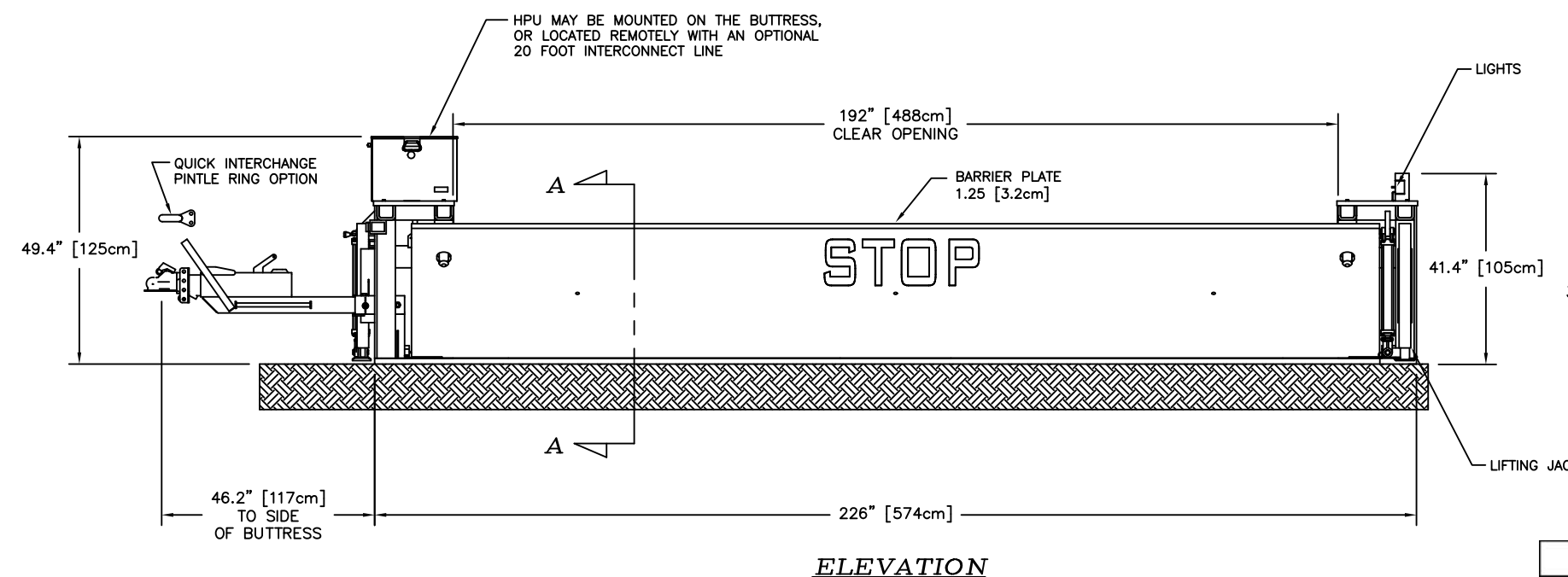

ELEVATION

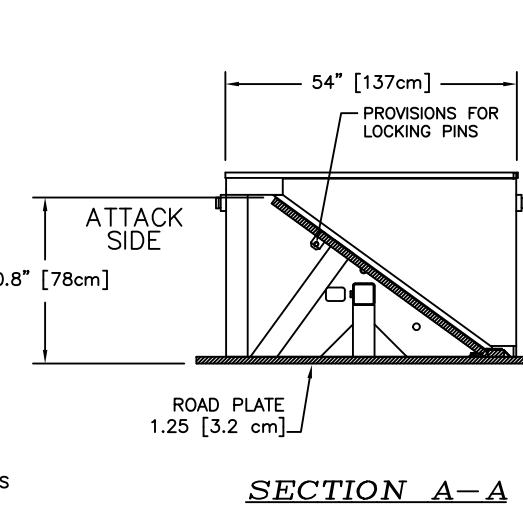

SECTION A-A

DESCRIPTION	WEIGHTS	
BARRIER ONLY	12,201 lbs	5,534 kg
TRAILER ONLY	1,159 lbs	526 kg
BARRIER W/TRAILER	13,360 lbs	6,060 kg
TONGUE @ 26" [66 cm] HIGH	775 lbs	352 kg



REV.	DESCRIPTION	DATE	APPV BY	DATE	REV.	DATE
H	ECO 2013-055	11/06/13	T.D.P			
G	ECO 2011-129	01/9/12	M.C.	J.M.	01/24/12	
F	ECO 2011-084	6/13/11	M.C.			
E	ECO 2011-071	5/16/11	M.C.			
D	ECO 2010-098	7/26/10	L.G.	DCM	7/20/10	
C	ECO 2010-060	4/15/10	L.G.	DCM	4/13/10	
B	ECO 2009-175	10/5/09	J.M.			
A	ECO 2008-097	8/29/08	JFW			

NOTES: 1. OPTION B2050 SELECT MTC-26, 24" HIGH BARRIER MOUNT OR MPL-20, 48" HIGH OFF BARRIER MOUNT.

UNLESS OTHERWISE NOTED DIMENSIONS ARE IN INCHES

DELTA SCIENTIFIC CORPORATION
40355 DELTA LANE
PALMDALE, CA 93551 U.S.A.
(661) 575-1100 FAX (661) 575-1109

MP5000 16' PORTABLE ROADWAY BARRIER GENERAL ARRANGEMENT

DRWN BY J. MANOR	DATE 11/8/05	DRAWING NO. 90121	REV. H
CHKD BY	DATE	SCALE: 1:18 (D SIZE)	SHEET 1 OF 2
APPV BY	DATE		

© 1998 ALL RIGHTS RESERVED

TOP VIEW

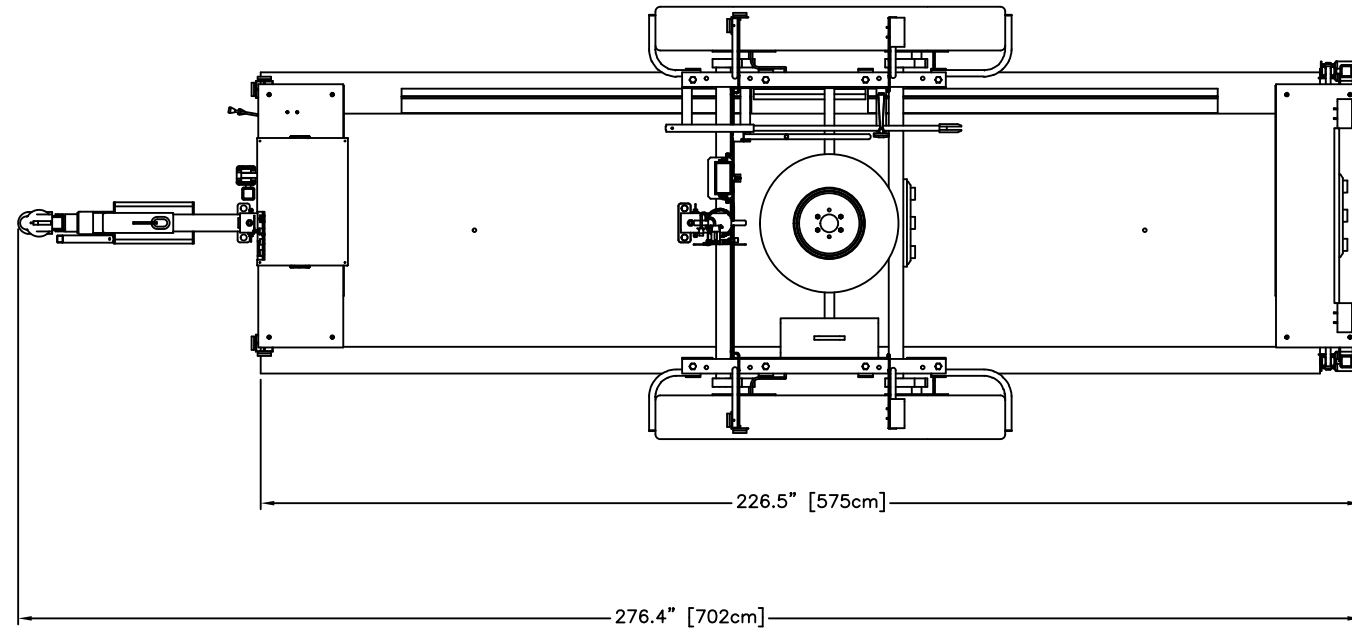

FRONT VIEW

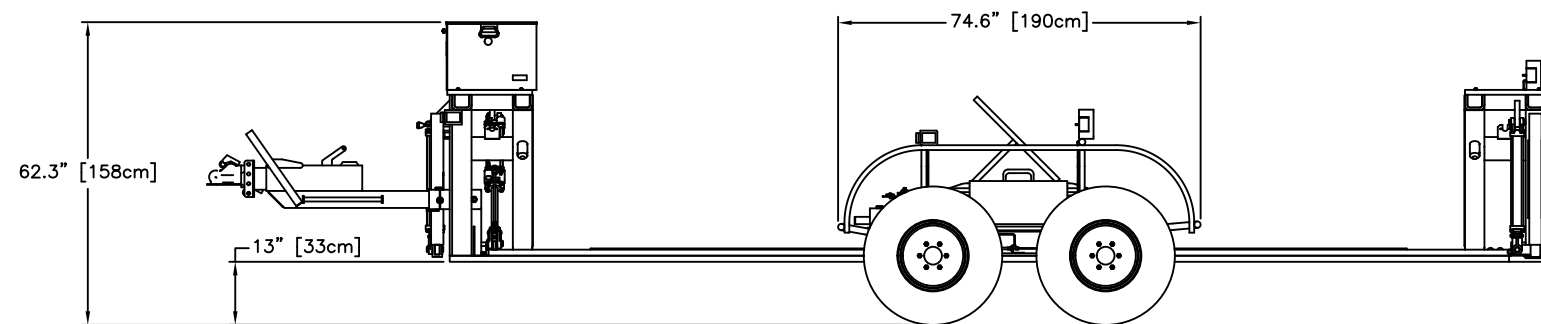
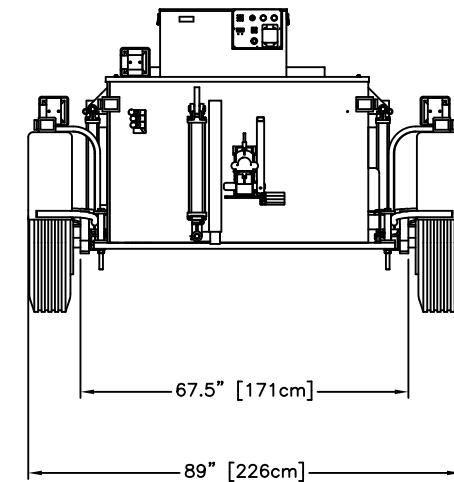

SIDE VIEW

<small>THIS DRAWING UNLESS OTHERWISE NOTED, REMAINS THE CONFIDENTIAL PROPERTY AND TRADE SECRET OF DELTA SCIENTIFIC CORPORATION. IT SHALL NOT BE DISCLOSED, REPRODUCED OR USED FOR CONSTRUCTION WITHOUT THE EXPRESS AUTHORIZATION OF DELTA SCIENTIFIC CORPORATION. THE RECIPIENT BY ACCEPTING THIS DRAWING, ASSUMES CUSTODY THEREOF AND UNDER THE ABOVE TERMS AGREES NOT TO ALLOW USE OF BY UNAUTHORIZED PERSONS.</small>	<small>UNLESS OTHERWISE NOTED DIMENSIONS ARE IN INCHES</small> TOLERANCES .X = ±.060/FT .XX = ±.030/FT .XXX = ±.010/FT ANGLES = ±.5° SURFACE FINISH 125	DELTA SCIENTIFIC CORPORATION 40355 DELTA LANE PALMDALE, CA 93551 U.S.A. (661) 575-1100 FAX (661) 575-1109			
		MP5000-20 TRAILER TOWING AND STORAGE SIZING G.A.			
		<small>DRWN BY</small> T.PERA	<small>DATE</small> 11/06/2013	<small>DRAWING NO.</small> 90121	<small>REV.</small> H
		<small>CHKD BY</small>	<small>DATE</small>	<small>SCALE:</small> 1:20	<small>SHEET</small> 2 OF 2

© 2013
ALL RIGHTS RESERVED

REMOVE ALL BURRS & BREAK SHARP EDGES .02 MAX